



PRONAR Sp. z o.o.

17-210 NAREW, UL. MICKIEWICZA 101A, WOJ. PODLASKIE, POLAND

Phone.:	+48 085 681 63 29	+48 085 681 64 29
	+48 085 681 63 81	+48 085 681 63 82
Fax:	+48 085 681 63 83	+48 085 682 71 10

www.pronar.pl

OPERATOR'S MANUAL

TRAILER

PRONAR T679/3

PRONAR T679/4

TRANSLATION OF THE ORIGINAL DOCUMENT

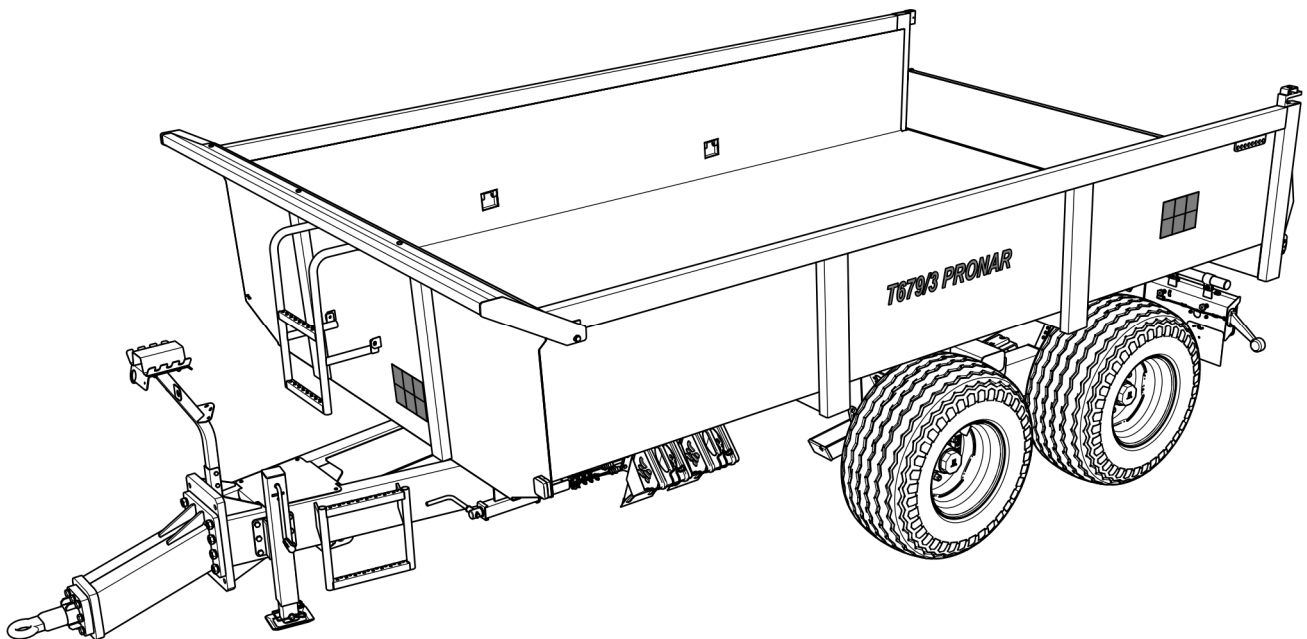

ISSUE 2A-06-2016

PUBLICATION NO. 537N-00000000-UM

EN

Thank you for purchasing our trailer. In the interests of your safety and care for the reliability and durability of the machine, we ask that you familiarise yourself with the content of this manual.

Remember!!!

Before using the trailer for the first time, check if the wheels are properly tightened!!! Regularly check the technical condition of the machine in accordance with the attached schedule.

INTRODUCTION

Information contained herein is current as of the date of its publication. As a result of improvements, some numerical values and illustrations contained in this publication may not correspond to the factual specification of the machine delivered to the user. The manufacturer reserves the right to introduce design changes in manufactured machines that facilitate operation and improve the quality of their work, without making amendments to this Operator's Manual.

This Operator's Manual is an integral part of the machine. Before using the machine, the user must carefully read this Operator's Manual and observe all recommendations. This guarantees safe operation and ensures malfunction-free work of the machine. The machine is designed to meet obligatory standards, documents and legal regulations currently in force.

The manual describes the basic safety and operation rules of Pronar T679/3, T679/4 trailer.

If the information contained in the Operator's Manual needs clarification, the user should refer for assistance to the sale point where the machine was purchased or to the manufacturer.

MANUFACTURER'S ADDRESS

*PRONAR Sp. z o.o.
ul. Mickiewicza 101A
17-210 Narew, Poland*

PHONE NUMBERS

<i>+48 085 681 63 29</i>	<i>+48 085 681 64 29</i>
<i>+48 085 681 63 81</i>	<i>+48 085 681 63 82</i>

SYMBOLS USED IN THIS MANUAL

Information, descriptions of danger, precautions, recommendations and orders associated with user safety instructions are indicated as follows:



and preceded by the word "**DANGER**". Failure to observe the instructions may endanger the machine operator's or other person's health or life.

Particularly important information and instructions, the observance of which is essential, are indicated with the sign:



and preceded by the word "**ATTENTION**". Failure to observe the instructions may lead to damage to the machine as a result of improper operation, adjustment or use.

In order to focus the user's attention on the need to perform periodical maintenance, the relevant section of the Operator's Manual is indicated with the sign:



Additional tips contained in this document refer to helpful information on the machine operation and are indicated as follows:



and preceded by the word "**TIP**".

DETERMINING THE DIRECTIONS FOR THE MANUAL'S NEEDS

Left side — a left hand side of the person facing the machine's forward travel direction.

Right side — a right hand side of the person facing the machine's forward travel direction.

SCOPE OF OPERATION STEPS

Operation steps are indicated with the following sign: ➡

The result of an operation/adjustment task or any notes on execution of the tasks performed is indicated with the sign ⇒



PRONAR Sp. z o.o.

ul. Mickiewicza 101 A
17-210 Narew, Polska

tel./fax (+48 85) 681 63 29, 681 63 81, 681 63 82,
681 63 84, 681 64 29

fax (+48 85) 681 63 83

http://www.pronar.pl

e-mail: pronar@pronar.pl

EC DECLARATION OF CONFORMITY OF THE MACHINERY

PRONAR Sp. z o.o. declares with full responsibility, that the machine:

Description and identification of the machinery		
Generic denomination and function:	AGRICULTURAL TRAILER	
Type:	T679/3	T679/4
Model:	-----	-----
Serial number:		
Commercial name:	AGRICULTURAL TRAILER PRONAR T679/3	AGRICULTURAL TRAILER PRONAR T679/4

to which this declaration relates, fulfills all the relevant provisions of the Directive **2006/42/EC** of The European Parliament and of The Council of 17 May 2006 on machinery, and amending Directive 95/16/EC (Official Journal of the EU, L 157/24 of 09.06.2006).

The person authorized to compile the technical file is the Head of Research and Development Department at PRONAR Sp. z o.o., 17-210 Narew, ul. Mickiewicza 101A, Poland.

This declaration relates exclusively to the machinery in the state in which it was placed on the market, and excludes components which are added and/or operations carried out subsequently by the final user.

Narew, the 2016-06-03

Place and date

ROMAN OMELIANUK
d/s technicznych
członek zarządu
Z-CA DZIAŁALNOŚĆ
PRONAR

*Full name of the empowered person
position, signature*

TABLE OF CONTENTS

1	BASIC INFORMATION	1.1
1.1	IDENTIFICATION	1.2
1.1.1	TRAILER IDENTIFICATION	1.2
1.1.2	HALF AXLE IDENTIFICATION	1.3
1.1.3	LIST OF SERIAL NUMBERS	1.4
1.2	INTENDED USE	1.4
1.3	EQUIPMENT	1.8
1.4	TERMS OF WARRANTY	1.10
1.5	TRANSPORT	1.11
1.5.1	TRANSPORT ON VEHICLE	1.11
1.5.2	INDEPENDENT TRANSPORT BY THE USER	1.13
1.6	ENVIRONMENTAL HAZARDS	1.14
1.7	WITHDRAWAL FROM USE	1.15
2	SAFETY ADVICE	2.1
2.1	SAFETY INFORMATION	2.2
2.1.1	BASIC SAFETY RULES	2.2
2.1.2	DRIVING ON PUBLIC ROADS	2.6
2.1.3	DESCRIPTION OF RESIDUAL RISK	2.7
2.2	INFORMATION AND WARNING DECALS	2.8
3	DESIGN AND OPERATION	3.1
3.1	TECHNICAL SPECIFICATION	3.2
3.2	TRAILER CONSTRUCTION	3.3
3.2.1	CHASSIS	3.3
3.2.2	LOAD BOX	3.5
3.2.3	MAIN BRAKE	3.6

3.2.4	HYDRAULIC TIPPING SYSTEM	3.7
3.2.5	TAILGATE HYDRAULIC SYSTEM	3.9
3.2.6	PARKING BRAKE	3.10
3.2.7	ELECTRIC LIGHTING SYSTEM	3.11
4	CORRECT USE	4.1
4.1	PREPARING THE TRAILER FOR WORK	4.2
4.1.1	PRELIMINARY INFORMATION	4.2
4.1.2	HAND-OVER AND INSPECTION OF THE MACHINE AFTER DELIVERY	4.2
4.1.3	PREPARING THE TRAILER FOR THE FIRST USE, TEST RUN OF THE TRAILER	4.3
4.1.4	PREPARING THE TRAILER FOR NORMAL USE	4.4
4.2	HITCHING AND UNHITCHING THE TRAILER	4.5
4.2.1	HITCHING AND UNHITCHING THE SECOND TRAILER	4.7
4.3	LOADING AND SECURING LOAD	4.9
4.3.1	GENERAL INFORMATION ABOUT LOADING	4.9
4.3.2	SECURING LOAD	4.10
4.4	TRANSPORTING LOADS	4.13
4.5	UNLOADING	4.15
4.6	PROPER USE AND MAINTENANCE OF TYRES	4.18
5	MAINTENANCE	5.1
5.1	PRELIMINARY INFORMATION	5.2
5.2	MAINTENANCE OF WHEEL AXLE	5.2
5.2.1	PRELIMINARY INFORMATION	5.2
5.2.2	CHECKING SLACKNESS OF WHEEL AXLE BEARINGS	5.3
5.2.3	ADJUSTMENT OF SLACKNESS OF WHEEL AXLE BEARINGS	5.5
5.2.4	MOUNTING AND DISMOUNTING WHEEL, INSPECTION OF WHEEL NUT TIGHTENING.	5.6

5.2.5	CHECKING AIR PRESSURE IN TYRES, EVALUATING TECHNICAL CONDITION OF TYRES AND STEEL WHEELS	5.8
5.2.6	CHECKING THICKNESS OF BRAKE SHOE LININGS	5.9
5.2.7	MECHANICAL BRAKES ADJUSTMENT	5.10
5.2.8	CHANGE OF PARKING BRAKE CABLE AND ADJUSTMENT OF CABLE TENSION.	5.16
5.3	PNEUMATIC SYSTEM MAINTENANCE	5.19
5.3.1	PRELIMINARY INFORMATION	5.19
5.3.2	CHECKING TIGHTNESS	5.19
5.3.3	INSPECTION OF THE SYSTEM	5.20
5.4	CLEANING THE AIR FILTERS	5.21
5.4.1	DRAINING WATER FROM AIR TANK	5.22
5.4.2	CLEANING DRAIN VALVE	5.22
5.4.3	CLEANING AND MAINTAINING PNEUMATIC CONDUIT CONNECTIONS AND PNEUMATIC SOCKETS	5.23
5.5	HYDRAULIC SYSTEM MAINTENANCE	5.24
5.5.1	PRELIMINARY INFORMATION	5.24
5.5.2	CHECKING HYDRAULIC SYSTEM TIGHTNESS	5.24
5.5.3	CHECKING TECHNICAL CONDITION OF HYDRAULIC CONNECTIONS AND SOCKETS.	5.25
5.5.4	REPLACEMENT OF HYDRAULIC CONDUITS	5.25
5.6	LUBRICATION	5.26
5.6.1	CONSUMABLES	5.29
5.7	TRAILER CLEANING	5.31
5.8	STORAGE	5.32
5.9	INSPECTION OF TIGHTENING TORQUE OF NUT AND BOLT CONNECTIONS	5.33
5.9.1	TIGHTENING TORQUE FOR NUT AND BOLT CONNECTIONS	5.33
5.10	ADJUSTMENT OF DRAWBAR POSITION	5.34
5.11	ADJUSTMENT OF TAILGATE POSITION	5.36

5.12 TROUBLESHOOTING

5.37

5.12.1 TROUBLESHOOTING

5.37

SECTION

1

**BASIC
INFORMATION**

1.1 IDENTIFICATION

1.1.1 TRAILER IDENTIFICATION

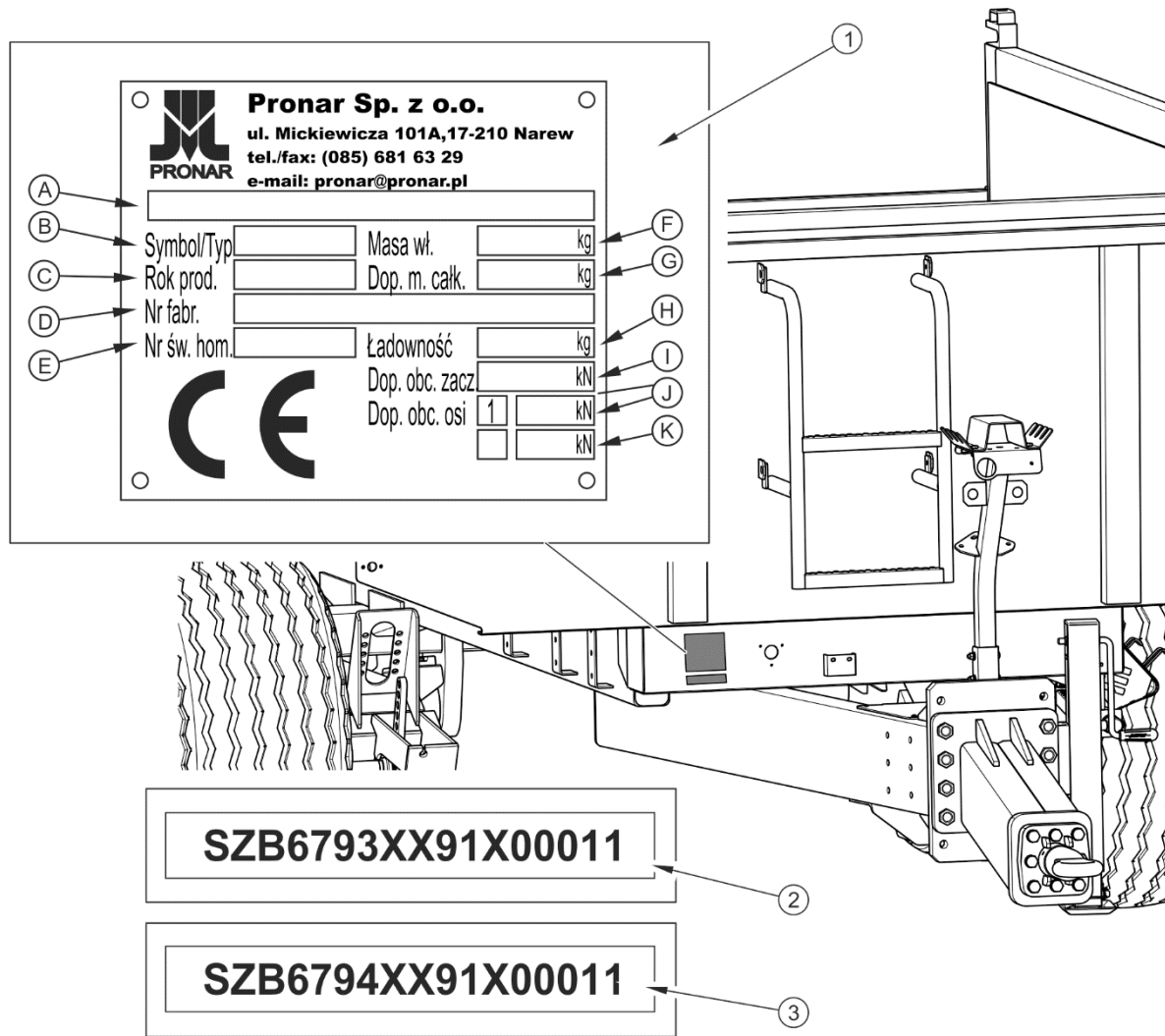

FIGURE 1.1 Location of the data plate and vehicle identification number (VIN)

(1) data plate, (2) example of VIN number for T679/3, (3) example of VIN number for T679/4

Pronar T679/3 and Pronar T679/4 agricultural trailers are marked with the data plate (1), vehicle identification number (VIN) (2) for T679/3 trailer and vehicle identification number (VIN) (3) for T679/4 trailer. The serial number and data plate are located on the right side of the frame front beam – figure (1.1). When buying the agricultural trailer check that the serial numbers on the machine agree with the number written in the *WARRANTY BOOK* and in the

sales documents. The meanings of the individual fields found on the data plate are presented in the table below:

TABLE 1.1 *Markings on data plate*

ITEM	MARK
A	General description and purpose
B	Symbol /Machine type
C	Year of manufacture
D	Seventeen digit vehicle identification number (VIN)
E	Official certificate number
F	Machine tare weight
G	Maximum gross weight
H	Carrying capacity
I	Permissible hitching system loading
J	Permissible front axle load
K	Permissible rear axle load

1.1.2 HALF AXLE IDENTIFICATION

The serial number of the half axle and its type are stamped onto data plate (3) secured to half axle shield (2). Two half axles connected permanently with a beam form suspension system rocker (1) – figure (1.2).



TIP

In the event of ordering a replacement part or in the case of the appearance of problems it is often essential to give the serial number of the trailer or the serial number of the half axle, therefore it is recommended that these numbers are inscribed in the table (1.2).

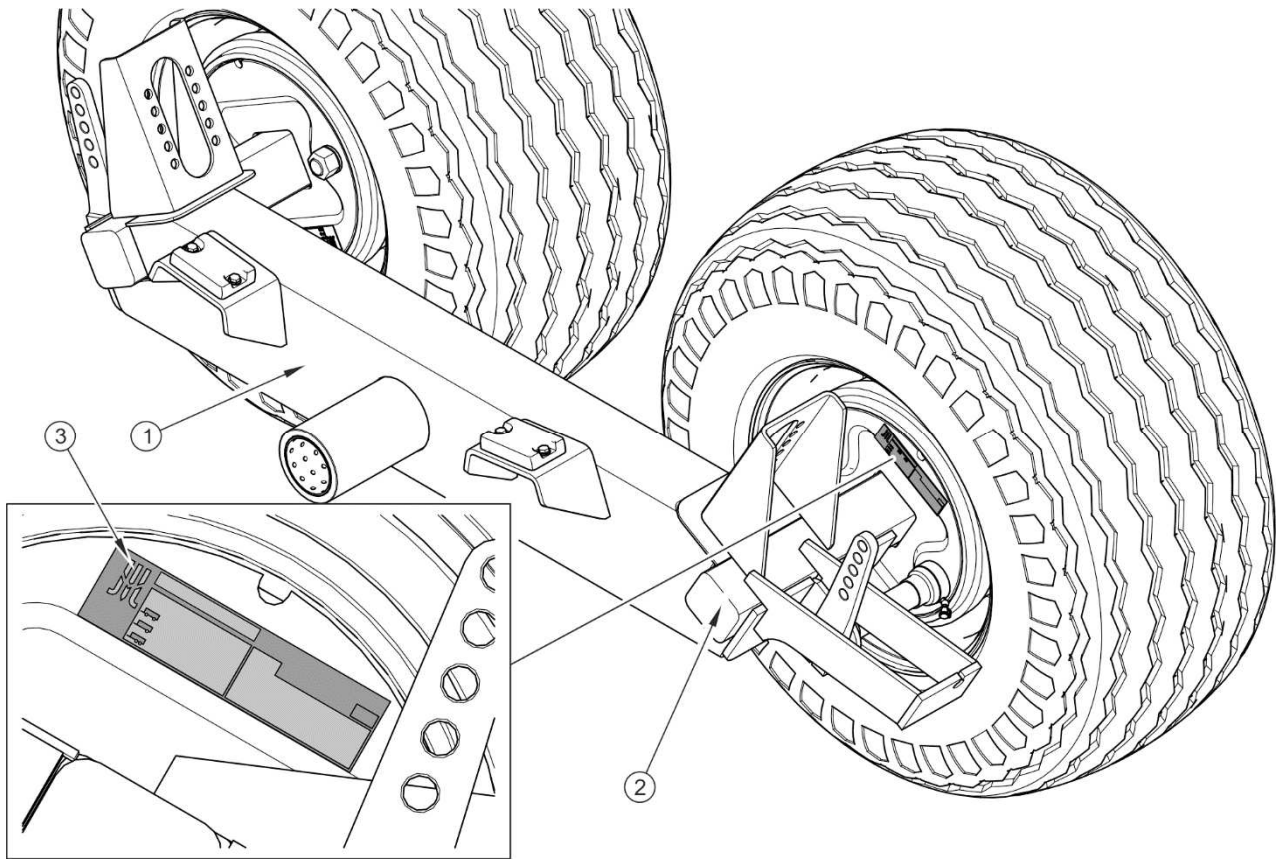

FIGURE 1.2 Location of the half axle data plate

(1) left rocker (2) half axle (3) data plate

1.1.3 LIST OF SERIAL NUMBERS

TABLE 1.2 List of serial numbers

VIN														
S	Z	B	6	7	9			X			X			
HALF AXLE SERIAL NUMBER														

1.2 INTENDED USE

The trailer is designed for transporting and unloading heavy materials such as: debris, stones, rubble, gravel, used during construction, the earthworks, demolition, on the farm and

on public roads. Load box design enables loading and transport of machinery and construction vehicles as well as transport of goods on EUR-pallets.

TABLE 1.3 *Recommended types of pallets*

PALLET NAME - TYPE	LENGTH [MM]	WIDTH [MM]	HEIGHT [MM]
EUR-pallet – standard	1,200	800	144
EUR-pallet – 1/2	800	600	144
EUR-pallet – extended	1,200	1,200	144
ISO	1,200	1,000	144

The above-mentioned loads may be transported provided that the recommendations included in this manual, especially the recommendations concerning protection of loads included in Section (4.3.2), are adhered to. The trailer is suitable for driving on public roads.

The trailer may only be hitched to the agricultural tractors which fulfil all the requirements specified in table (1.4).

DANGER

The trailer must not be used for purposes other than those for which it is intended, in particular:



- *for transporting people and animals,*
- *for transporting hazardous loads or loads which are not properly secured against shifting or falling out,*
- *for transporting loads which are unevenly distributed and/or which overload half axles and suspension elements; do NOT overload the trailer in excess of its load carrying capacity,*
- *for transporting any materials other than those stipulated in the manual.*

The brake system and the lighting and indicator system meet the requirements of road traffic regulations. Do NOT exceed the permissible speed of the tractor-trailer combination (the permissible speed in force in the country in which the trailer is used). The trailer speed must not, however, be greater than the maximum design speed of 40 km/h.

Using it as intended also involves all actions connected with the safe and proper operation and maintenance of the machine. Due to the above, the user is obliged to:

- carefully read the *OPERATOR'S MANUAL* and *WARRANTY BOOK* and conform with the recommendations contained in these documents,
- understand the machine's operating principle and how to operate it safely and correctly,
- adhere to the established maintenance and adjustment plans,
- comply with general safety regulations while working,
- prevent accidents,
- comply with the road traffic regulations and transport regulations in force in a given country, in which the machine is used,
- carefully read the Operator's Manual and comply with its recommendations,
- only hitch the trailer to an agricultural tractor, which fulfils all the requirements made by the trailer's Manufacturer.

TABLE 1.4 *Agricultural tractor's requirements*

CONTENTS	UNIT	REQUIREMENTS
Brake system connection sockets		
Single conduit pneumatic system	-	according to A DIN 74 294 according to ISO 1728 according to ISO 7421-1
Double conduit pneumatic system	-	
Hydraulic system	-	
Pressure rating of the system		
Single conduit pneumatic system	bar	5.8 – 6.5
Double conduit pneumatic system	bar	6.5
Hydraulic system	bar	150
Hydraulic system		
Hydraulic oil	-	L HL 32 Lotos ⁽¹⁾
Maximum system pressure	bar	200
Oil demand:	l	17

CONTENTS	UNIT	REQUIREMENTS	
Electrical system			
Electrical system voltage	V	12	
Connection socket	-	7-pole compliant with ISO 1724	
Tractor hitches			
Type of hitch	-	upper or lower transport hitch	
Other requirements		679/3	679/4
Minimum tractor power	hp / /kW	69.4 / 51	62.6 / 46
Minimum vertical load capacity of hitch	kg	1,800	1,500

⁽¹⁾ – use of other oil is permitted, on condition that it may be mixed with the oil in the trailer. Detailed information may be found on the product information card.

The machine may only be used by persons, who:

- are familiar with the contents of this publication and with the contents of the agricultural tractor Operator's Manual,
- have been trained in trailer operation and safe operation,
- have the required authorisation to drive and are familiar with the road traffic regulations and transport regulations.

In the event that the trailer shall be hitched to a second trailer it must fulfil the requirements stipulated in table (1.4).

TABLE 1.5 Requirements for second trailer

CONTENTS	UNIT	REQUIREMENTS	
Maximum gross weight	kg	T679/3	T679/4
		13,000	11,000

CONTENTS	UNIT	REQUIREMENTS
Brake system - connectors		
Single conduit pneumatic system	-	according to A DIN 74 294
Double conduit pneumatic system	-	according to ISO 1728
Hydraulic system	-	according to ISO 7421-1
Maximum system pressure		
Single conduit pneumatic system	bar	5.8 – 6.5
Double conduit pneumatic system	bar	6.5
Hydraulic system	bar	150
Hydraulic tipper system		
Hydraulic oil	-	L HL 32 Lotos ⁽¹⁾
Maximum system pressure	bar	200 / 20
Electrical system		
Electrical system voltage	V	12
Connection socket	-	7-pole compliant with ISO 1724
Drawbar of trailer		
Diameter of drawbar eye	mm	40

⁽¹⁾ – use of other oil is permitted, on condition that it may be mixed with the oil in the trailer. Detailed information may be found on the product information card.

1.3 EQUIPMENT

TABLE 1.6 Equipment

EQUIPMENT	STANDARD	ADDITIONAL	OPTION
OPERATOR'S MANUAL, WARRANTY BOOK	•		
Adjustable drawbar	•		
Rotating drawbar eye Ø50	•		

EQUIPMENT	STANDARD	ADDITIONAL	OPTION
Fixed drawbar eye Ø40			•
Ball drawbar K80			•
Load box made of wear resistant steel plates			•
Rear hitch		•	
Double line pneumatic braking system			•
Hydraulic brake system	•		
Hydraulic tipper system	•		
Hydraulic hinged tailgate	•		
Hinged-opening tailgate			•
Parking brake	•		
Lighting system LED 12V	•		
Lights support beams with rear lamp shields	•		
Slow-moving vehicle warning sign		•	
Load box service support	•		
800mm load box extensions		•	
Mechanical telescopic drawbar support	•		
Load box ladder	•		
Front canopy of load box		•	
Warning reflective triangle		•	
Wheel chocks	•		

**TIP**

Information concerning tyres is provided at the end of this manual in ANNEX A.

1.4 TERMS OF WARRANTY

**TIP**

Demand that the seller carefully and precisely fills out the WARRANTY BOOK and warranty repair coupons. A missing date of purchase or sale point stamp, may make the user ineligible for any warranty repair or refund.

PRONAR Sp. z o.o. Narew guarantees the reliable operation of the machine when it is used according to its intended purpose as described in the *OPERATOR'S MANUAL*. The repair period is specified in the *WARRANTY BOOK*.

The warranty does not cover those parts and sub-assemblies of the machine which are subject to wear in normal usage conditions, regardless of the warranty period. Consumables include the following parts/sub-assemblies:

- drawbar hitching eye,
- pneumatic system connector filters,
- tyres,
- seals,
- bearings,
- LED lamps,
- brake shoes.

The warranty service only applies to factory defects and mechanical damage that is not due to the user's fault.

In the event of damage arising from:

- mechanical damage which is the user's fault, road accidents,

- inappropriate use, adjustment or maintenance, use of the machine for purposes other than those for which it is intended,
- use of damaged machine,
- repairs carried out by unauthorised persons, repairs carried out improperly,
- making unauthorised alterations to machine design,

the user will lose the right to warranty service.

The user is obliged to report immediately on noticing any wear in the paint coating or traces of corrosion, and to have the faults rectified whether they are covered by the warranty or not. For detailed Terms & Conditions of Warranty, please refer to the *WARRANTY BOOK* attached to each machine.

Modification of the machine without the written consent of the Manufacturer is forbidden. In particular, do NOT weld, drill holes in, cut or heat the main structural elements of the machine, which have a direct impact on the machine operation safety.

1.5 TRANSPORT

The machine is prepared for sale completely assembled and does not require packing. Packing is only required for the machine's technical documentation and any extra fittings. The agricultural trailer is delivered to the user either transported on a vehicle or, after being attached to a tractor, independently (towing with a tractor).

1.5.1 TRANSPORT ON VEHICLE

Loading and unloading of the agricultural trailer from vehicle shall be conducted using loading ramp with the aid of agricultural tractor, overhead crane or hoisting crane. During work adhere to the general principles of Health and Safety at Work applicable to reloading work. Persons operating reloading equipment must have the qualifications required to operate these machines.

Lifting equipment used for transporting the machine must be attached only to the fixed structural elements of the machine. These elements are, first of all: frame and transport lugs.

ATTENTION



Do not attach or hitch the trailer by drawbar eye or other structural elements that are not sufficiently strong to withstand operations of this type.

The trailer should be attached firmly to the platform of the vehicle using straps or chains fitted with a tightening mechanism. In order to attach the machine in a proper manner, use transport lugs (1) – figure (1.3), and fasten half axles, lower longitudinal members of the frame and possibly drawbar elements.

Chocks, wooden blocks or other objects without sharp edges should be placed under the wheels of the trailer to prevent it from rolling. Wheel blocks must be nailed to the vehicle load platform planks or secured in another manner preventing their movement.

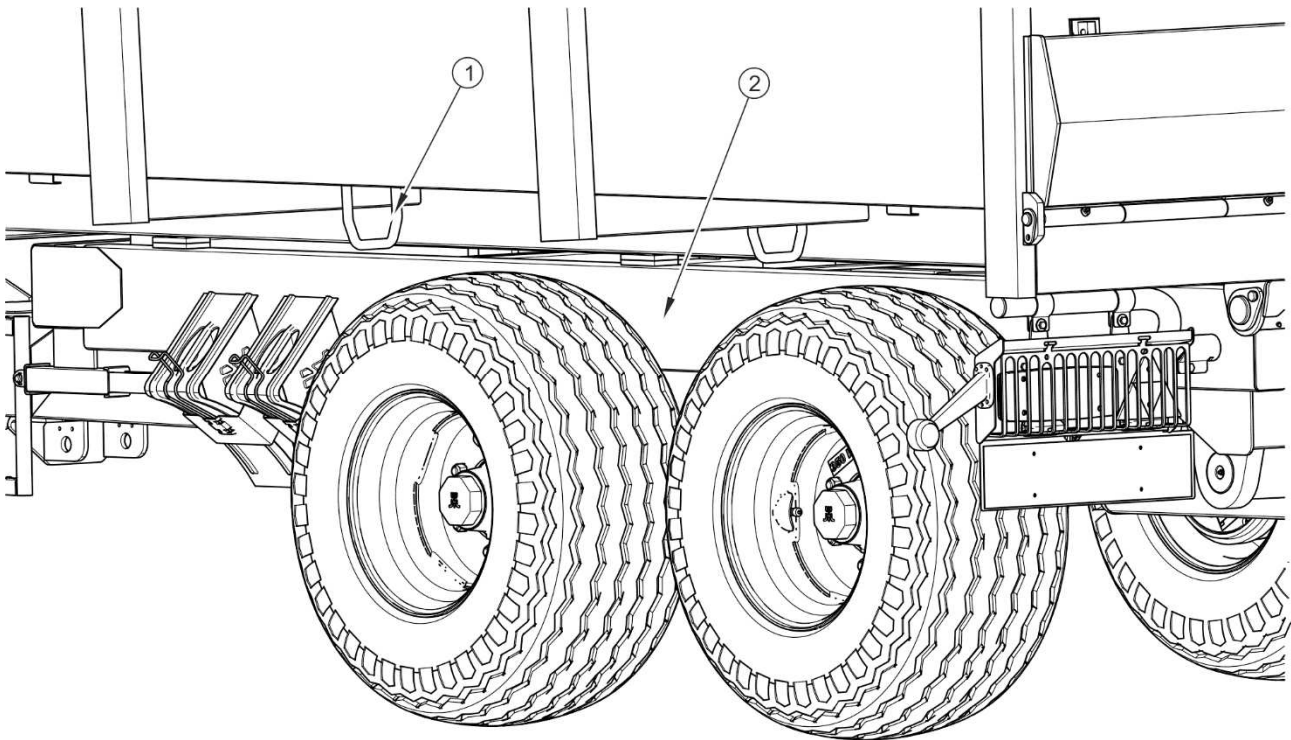

FIGURE 1.3 *Transport lugs*

(1) transport lug, (2) lower longitudinal member



DANGER

Incorrect use of securing measures may cause an accident.

Use certified and technically reliable securing measures. Worn straps, cracked securing catches, bent or corroded hooks as well as elements damaged in a different way may be unsuitable for use. Carefully read the information stated in the Operator's Manual for the given securing measure. The number of securing elements (cables, straps, chains and stays etc.) and the force necessary for their tensioning depend on such factors as the trailer weight, the carrying vehicle design, speed of travel and other conditions. For this reason it is impossible to define the securing plan precisely.

A correctly secured machine does not change its position with regard to the transporting vehicle. The securing elements must be selected according to the guidelines of the Manufacturer of these elements. In case of doubt apply a greater number of securing straps in order to immobilise the machine. If necessary, sharp edges of trailer should be protected at the same time protecting the securing straps from breaking during transport.

ATTENTION



When being road transported on a motor vehicle the trailer must be mounted on the vehicle's platform in accordance with the transport safety requirements and the regulations.

Driver of the vehicle should be particularly careful during travel. Centre of gravity of the vehicle transporting the machine is shifted upwards, which poses a threat to stability of the vehicle and transported machine.

Use only certified and technically reliable securing measures. Carefully read the manufacturer's instructions for the securing measures.

During reloading work, particular care should be taken not to damage parts of the machine's fittings or the paint coating. The tare weight of the agricultural trailer is given in table (3.1).

1.5.2 INDEPENDENT TRANSPORT BY THE USER

In the event of independent transport by the user, carefully read *THE OPERATOR'S MANUAL* and follow its recommendations. Independent transport involves towing the machine with own agricultural tractor to destination. During transport adjust travel speed to the prevailing road conditions, but do not exceed the maximum design speed.

ATTENTION



Before transporting independently, the tractor driver must carefully read this

Operator's Manual and observe its recommendations.

1.6 ENVIRONMENTAL HAZARDS

A hydraulic oil leak constitutes a direct threat to the natural environment owing to its limited biodegradability. The negligible solubility of hydraulic oil in water does not cause extreme toxicity of organisms living in the aquatic environment. The formation of a film of oil on the water may be the direct cause of physical action on organism, perhaps causing change of oxygen values in the water because of lack of direct contact of air with the water. An oil leak into water reservoirs may however lead to a reduction of the oxygen content.



DANGER

Used hydraulic oil or gathered remains mixed with absorbent material should be stored in a precisely marked container. Do not use food packaging for this purpose.

While carrying out maintenance and repair work, which involves the risk of an oil leak, this work should take place on an oil resistant floor or surface. In the event of oil leaking into the environment, first of all contain the source of the leak, and then collect the leaked oil using available means. Remaining oil should be collected using sorbents, or by mixing the oil with sand, sawdust or other absorbent materials. The oil pollution, once gathered up, should be kept in a sealed, marked, hydrocarbon resistant container. The container should be kept away from heat sources, flammable materials and food.



ATTENTION

Waste oil should only be taken to the appropriate facility dealing with the re-use of this type of waste. Do NOT throw or pour oil into sewerage or water tanks.

Oil, which has been used up or is unsuitable for further use owing to a loss of its properties should be stored in its original packaging in the conditions described above. Waste oil should be taken to the appropriate facility dealing with the re-use of this type of waste. Waste code (L-HL 32 Lotos hydraulic oil): 13 01 10. Detailed information concerning hydraulic oil may be found on the product's Material Safety Data Sheet.

**TIP**

The hydraulic system of the trailer is filled with L-HL32 Lotos hydraulic oil.

1.7 WITHDRAWAL FROM USE

In the event of decision by the user to withdraw the machine from use, comply with the regulations in force in the given country concerning withdrawal from use and recycling of machines withdrawn from use. Before proceeding to dismantle equipment, oil shall be completely removed from hydraulic system.

Worn out or damaged parts that cannot be reclaimed should be taken to a collection point for recyclable raw materials. Hydraulic oil should be taken to the appropriate facility dealing with the re-use of this type of waste.

**DANGER**

During dismantling, use the appropriate tools, equipment (overhead travelling crane, crane or hoist etc.) and use personal protection equipment, i.e. protective clothing, footwear, gloves and eye protection etc.

Avoid contact of skin with oil. Do not allow used hydraulic oil to spill.

SECTION

2

SAFETY ADVICE

2.1 SAFETY INFORMATION

2.1.1 BASIC SAFETY RULES

- Before using the trailer, the user must carefully read this operator's manual. When operating the machine, the operator must comply with the recommendations. The trailer may only be used and operated by persons qualified to drive agricultural tractors and trained in the use of the machine.
- If the information stated in the Operator's Manual is difficult to understand, contact a seller who runs an authorised technical service on behalf of the Manufacturer, or contact the Manufacturer directly.
- Careless and improper use and operation of the trailer, and non-compliance with the recommendations given in this operator's manual is dangerous to your health.
- Be aware of the existence of a residual risk, and for this reason the fundamental basis for using this machine should be the application of safety rules and sensible behaviour.
- The trailer must never be used by persons, who are not authorised to drive agricultural tractors, including children and people under the influence of alcohol or other drugs.
- Non-compliance with the safety rules of this Operator's Manual can be dangerous to the health and life of the operator and others.
- The trailer must not be used for purposes other than those for which it is intended. Anyone who uses the machine other than the way intended takes full responsibility for himself for any consequences of this use. Use of the trailer for purposes other than those for which it is intended by the Manufacturer may invalidate the warranty.
- Any modification to the trailer frees the manufacturer from any responsibility for damage or detriment to health, which may arise as a result.
- The trailer can only be stood on when it is absolutely motionless and the tractor engine is switched off. Use safe and resistant platforms or ladders of proper height.

- In the event of failure of the braking system, do not use the trailer until the malfunction is corrected.
- The trailer unhitched from tractor must be immobilised with parking brake. If the machine is positioned on a slope or elevation it shall be additionally secured against moving by placing chocks or other objects without sharp edges under the trailer's wheels.
- People or animals must not be carried on the trailer.
- The trailer and tractor must not be attached if the hydraulic oil in the two machines is of different types.
- The machine must not be used when not in working order.
- Do NOT exceed the trailer's maximum carrying capacity. Exceeding the carrying capacity may lead to damage to the machine, loss of stability while driving, scattering of the load and danger while working or driving.
- Before each use of the trailer, check the technical condition of the trailer and tractor hitching system and connection elements of the braking system and electrical system.
- Exercise caution when connecting and disconnecting machine from the tractor.
- Do NOT couple a second trailer if it does not fulfil the requirements specified by the Manufacturer (lack of required drawbar eye, exceeding permissible total weight, etc.) – compare table (1.3) *REQUIREMENTS FOR SECOND TRAILER*. Before connecting machines make certain that the oil in both trailers may be mixed.
- Only double axle trailers may be hitched to the trailer.
- When hitching, there must be nobody between the trailer and the tractor.
- When hitching the trailer to the tractor, use only the upper or lower transport hitch, depending on type of drawbar hitching eye and drawbar setting. Check safety clips.
- Load on the trailer must be uniformly distributed.

- Keep a safe distance during loading and unloading. Do not allow anyone to approach the place where works are carried out.
- Load should be protected against moving by means of belts, chains and tapes or other securing measures. The securing measures must be fitted with a tightening mechanism and have proper safety certificates.
- Condition of hydraulic systems must be frequently checked. Oil leaks in the systems are not allowed.
- Regularly check the technical condition of the connections and the pneumatic and hydraulic conduits.
- When connecting the hydraulic conduits to the tractor, make sure that the tractor's hydraulic system and the trailer's hydraulic system are not under pressure.
- Before beginning repair or maintenance works on pneumatic or hydraulic systems reduce air or oil pressure.
- In the event of injuries being caused by pressurised hydraulic oil, contact a doctor immediately. Hydraulic oil may find its way under the skin and cause infections.
- Use the hydraulic oil recommended by the Manufacturer. Never mix two types of oil.
- After changing the hydraulic oil, the used oil should be properly disposed of.
- When working on the tyres, chocks or other objects without sharp edges should be placed under the wheels of the trailer to prevent it from rolling. Wheels can be taken off the trailer axle only when the trailer is not loaded.
- The paint coating should be cleaned off before beginning welding work. Burning paint fumes are poisonous for people and animals. Welding work should be carried out in a well lit and well ventilated space.
- During welding work pay attention to flammable and fusible elements (parts of the hydraulic, pneumatic and electric systems, plastic and rubber parts). If there is a risk that they will catch fire or be damaged, they should be removed before commencing welding work.
- Repair work on the wheels or tyres should be carried out by persons trained and entitled to do so. This work should be carried out using appropriate tools.

- Inspect tightness of wheel nuts after the first use of the trailer, every 2 - 3 hours during the first month of work and then every 30 hours of use (travel). The inspection should be repeated individually if a wheel has been removed from the wheel axle. Wheel nuts should be tightened according to recommendations provided in section 5 MAINTENANCE.
- Check the tyre pressure regularly.
- In the event of any fault or damage whatsoever, do not use the trailer until the fault has been fixed. The trailer must not be used when not in working order.
- When operating the machine wear protective gloves and close fitting clothing and use the appropriate tools.
- Servicing and repair work should be carried out in line with the general principles of workplace health and safety. In the event of injury, the wound must be immediately cleaned and disinfected. In the event of more serious injuries, seek a doctor's advice.
- Repair, maintenance and cleaning work should be carried out with the tractor engine turned off and the ignition key removed.
- Regularly check the condition of the bolt and nut connections.
- Before welding or electrical work, the trailer should be disconnected from the power supply.
- During the warranty period, any repairs may only be carried out by Warranty Service authorised by the manufacturer.
- Should it be necessary to change individual parts, use only original parts. Non-adherence to these requirements may put the user and other people's health and life at risk, and also damage the machine and invalidate the warranty.
- In the event of work requiring the trailer to be raised, use properly certified hydraulic or mechanical lifts for this purpose. After lifting the trailer, stable and durable supports must also be used. Work must not be carried out under a trailer, which has only been raised with a lift or jack.
- The trailer must not be supported using fragile elements (bricks or concrete blocks).

- After completing work associated with lubrication, remove excess oil or grease.
- Use appropriate tools, close-fitting protective clothing and gloves when operating, maintaining or cleaning the machine.

2.1.2 DRIVING ON PUBLIC ROADS

- Comply with the road traffic regulations.
- Exceeding the maximum load capacity of the trailer may damage it, and also threaten the safety of traffic.
- Do not exceed the maximum speed limit. Adjust driving speed to the road conditions.

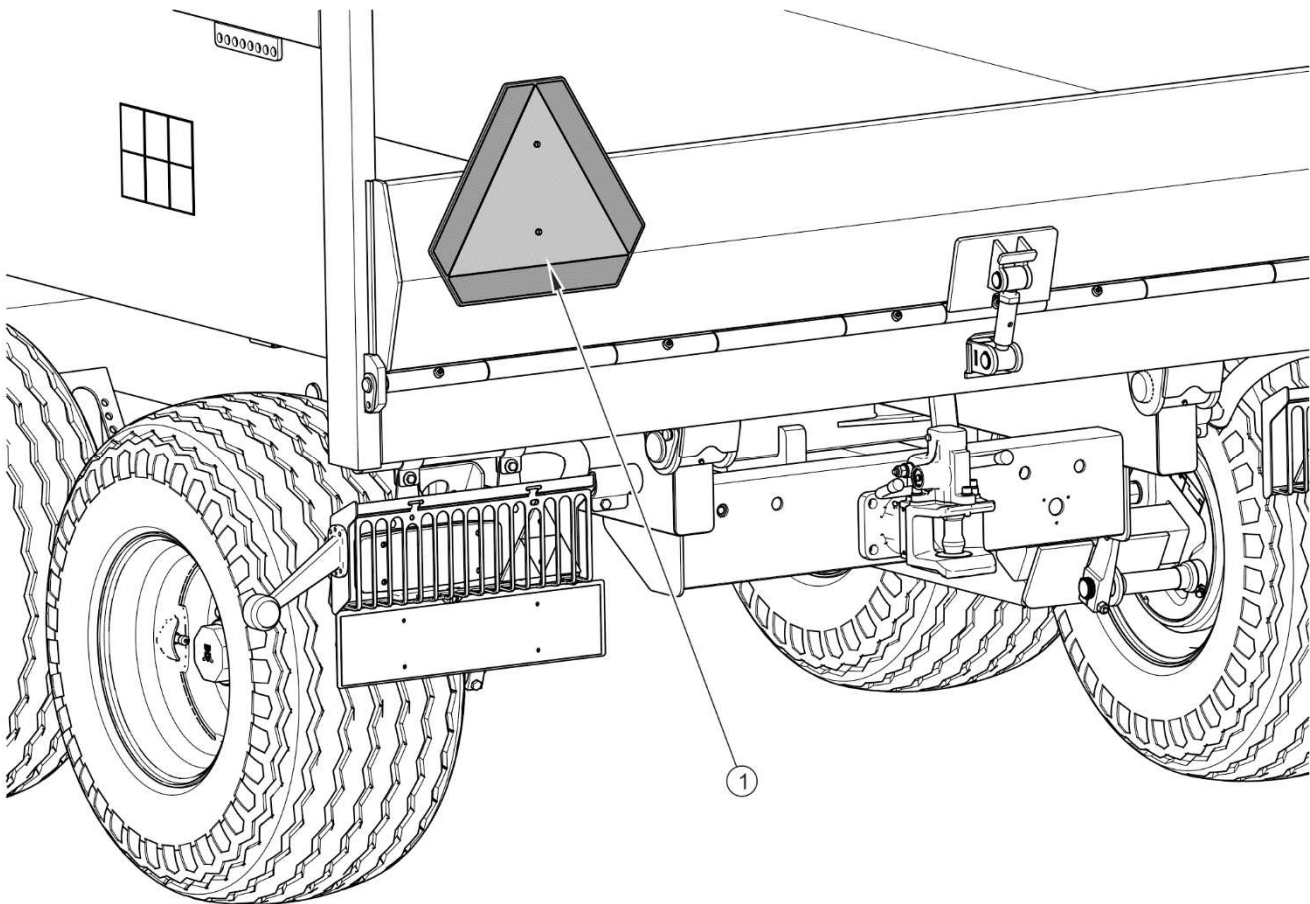

FIGURE 2.1 *Mounting place for the slow-moving vehicle warning sign*

(1) slow-moving vehicle warning sign

- The trailer must NOT be left unsecured. Securing the trailer involves immobilising the trailer with the parking brake and, optionally, placing chocks under trailer wheels.
- While driving on public roads the trailer must be fitted with a certified or authorised reflective warning triangle.
- Do not drive on public roads with raised load box. Driving with hazardous loads is forbidden.
- While driving on public roads the trailer shall be marked with a slow-moving vehicle warning sign attached to the tailgate.

2.1.3 DESCRIPTION OF RESIDUAL RISK

Pronar Sp. z o. o. in Narew has made every effort to eliminate the risk of accidents. There is, however, a certain residual risk, which could lead to an accident, and this is connected mainly with the actions described below:

- using trailer for purposes other than those described in the Operator's Manual,
- being between the tractor and the trailer while the engine is running and when the machine is being attached,
- operation of the trailer by persons under the influence of alcohol or other intoxicating substances,
- operation of the trailer by unauthorised persons,
- being on the machine when it operates,
- careless cleaning, maintenance and technical checks of the trailer.

The residual risk may be kept to a minimum by following the recommendations below:

- prudent and unhurried operation of the machine,
- sensible application of the remarks and recommendations contained in the Operator's Manual,
- maintaining safe distance from forbidden or dangerous places,
- a ban on being on the machine when it is operating,
- carrying out repair and maintenance work by persons trained to do so,



- using close fitting protective clothing,
- ensuring unauthorised persons have no access to the machine, especially children.

2.2 INFORMATION AND WARNING DECALS

The trailer is labelled with the information and warning decals mentioned in table (2.1). Locations of pictograms on the machine are shown in figure (2.2). Throughout the time it is in use, the user of the machine is obliged to take care that notices and warning and information symbols located on the trailer are clear and legible. In the event of their destruction, they must be replaced with new ones. Information and warning decals may be purchased directly from the Manufacturer or your PRONAR dealer. Part numbers of information decals are given under pictogram description in table (2.1) and in *SPARE PARTS LIST*. New assemblies, changed during repair, must be labelled once again with the appropriate safety signs. During agricultural trailer cleaning do not use solvents which may damage the coating of information label stickers and do not subject them to strong water jets.

TABLE 2.1 *Information and warning decals*

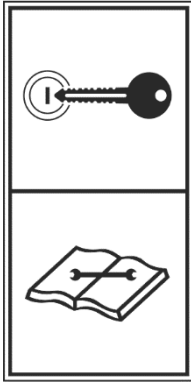
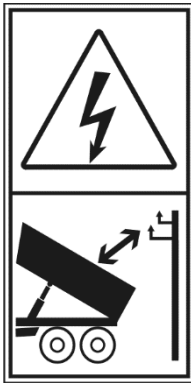
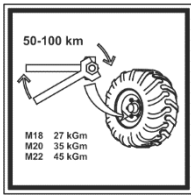
ITEM	SYMBOL	MEANING
1		<p style="text-align: center;">Caution!</p> <p style="text-align: center;">Before starting work, carefully read the <i>OPERATOR'S MANUAL</i>.</p> <p>70N-00000004</p>

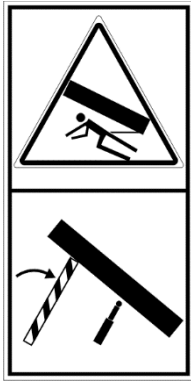
ITEM	SYMBOL	MEANING
2		<p>Before beginning servicing or repairs, turn off engine and remove key from ignition</p> <p>70N-0000005</p>
3		<p>Caution!</p> <p>Danger of electric shock.</p> <p>Keep a safe distance from electric power lines during unloading.</p> <p>58N-0000020</p>
4		<p>Regularly check if the nuts and bolts fixing the wheels and other components are properly tightened.</p> <p>104N-0000006</p>
5		<p>Grease the machine according to the recommendations in the <i>OPERATOR'S MANUAL</i></p> <p>104N-0000004</p>
6		<p>Danger of crushing</p> <p>Do NOT perform any maintenance or repairs on the load box that is loaded, raised or not supported.</p> <p>58N-0000012</p>

ITEM	SYMBOL	MEANING
7		<p>Danger of crushing Maintain a safe distance during opening and closing the tailgate.</p> <p>96N-0000006</p>
8	<p><i>PRONAR T679/3</i></p>	<p>Machine type.</p> <p>537N-0000001</p>
9	<p><i>PRONAR T679/4</i></p>	<p>Machine type.</p> <p>537N-0000002</p>

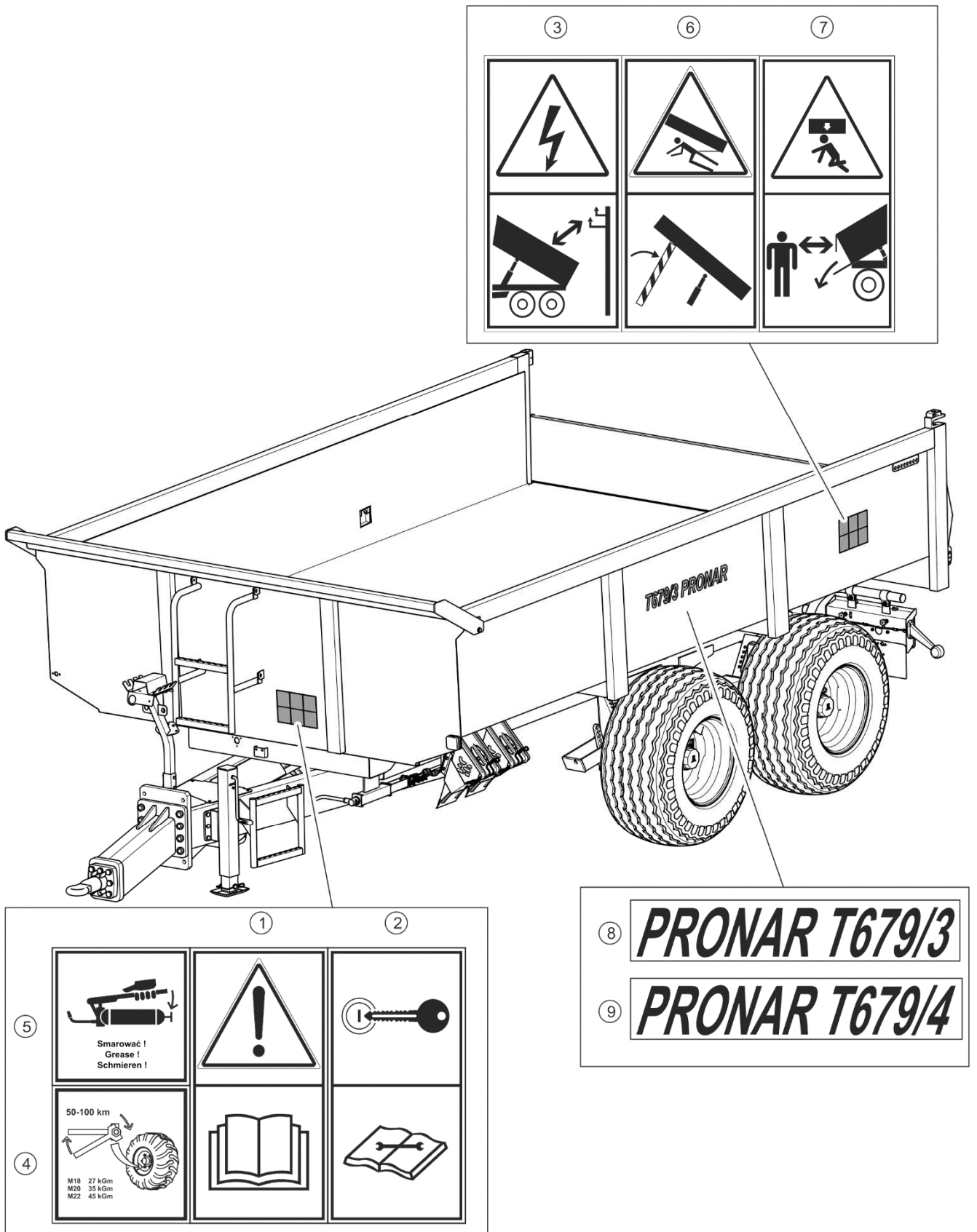

FIGURE 2.2 Locations of information and warning decals.

SECTION

3

**DESIGN AND
OPERATION**

3.1 TECHNICAL SPECIFICATION

TABLE 3.1 *Basic technical data of the standard machine version*

CONTENTS	UNIT	T679/3	T679/4
Dimensions			
Total length	mm	5,674	5,674
Total width	mm	2,550	2,550
Total height	mm	1,775	1,740
Load box dimensions			
Length	mm	4,000	4,000
Width	mm	2,416	2,420
Height	mm	648	650
Technical specification			
Maximum carrying capacity	kg	10,360	8,385
Maximum gross weight	kg	13,200	11,000
Tare weight	kg	2,840	2,615
Load surface	m ²	9.7	9.7
Other information			
Wheel track	mm	1,990	1,990
Maximum drawbar load	kg	1,500	1,800
Cargo capacity	m ³	6.4	6.4
Height of platform from the ground	mm	1,085	1,050
Load box tipping angle - to the rear	(°)	50	50
Electrical system voltage	V	12	12
Hydraulic oil demand	L	13	13
Hydraulic system pressure	MPa / bar	20 / 200	20 / 200
Tractor power demand	kW / Horsepower	51 / 69.4	46 / 62.6
Maximum design speed	km/h	40	40
Noise emission level	dB	below 70	below 70

3.2 TRAILER CONSTRUCTION

3.2.1 CHASSIS

Trailer chassis consists of subassemblies indicated in figure (3.1). Lower frame (1) is a structure welded from steel sections. The main support elements of the frame are two longitudinal members connected with crossbars. In the middle section there are sockets (5) used for mounting the tipping hydraulic cylinder. Load box support (10) is mounted in front of the sockets of the tipping cylinder. At the rear of the frame there is a rear beam serving as swivel point during the tipping of the load box to the rear. Under the beam there is a rear hitch socket to which the hitch (12) is attached, and hydraulic and pneumatic system sockets for connecting the second trailer. On both sides, at the rear of the frame, lights support beams (7) are bolted.

The trailer tandem suspension consists of two trailing arms (9). Two half axles are welded to each trailing arm (8). This suspension is the bogie suspension system. The trailing arms are attached to the frame by means of pins mounted in the slide bearings of lower frame (1) and trailing arms (9). The half axles are made from square bar ended with a pin on which the hub is mounted with the use of cone bearings. The wheels are single and equipped with shoe brakes activated by mechanical cam expanders.

In the front part of the chassis, there is mechanical parking stand (3), which supports the trailer disconnected from the tractor. Next to the support, conduit bracket (13) is bolted to lower frame (1). The bracket is used for storing and securing the plugs and sockets of the trailer system conduits.

Parking brake crank mechanism (1) is located on the left side of the lower frame. Drawbar (2) is bolted to the faceplate of the lower frame. Location of the drawbar can be adjusted depending on the tractor hitch (upper or lower) used to hitch the trailer. Rotating drawbar eye (10) with the eye of $\varnothing 50$ mm is attached to the drawbar faceplate in the lower position. Optionally, fixed drawbar eye with the eye diameter of $\varnothing 40$ mm is mounted to the trailer with the drawbar in the upper transport position.

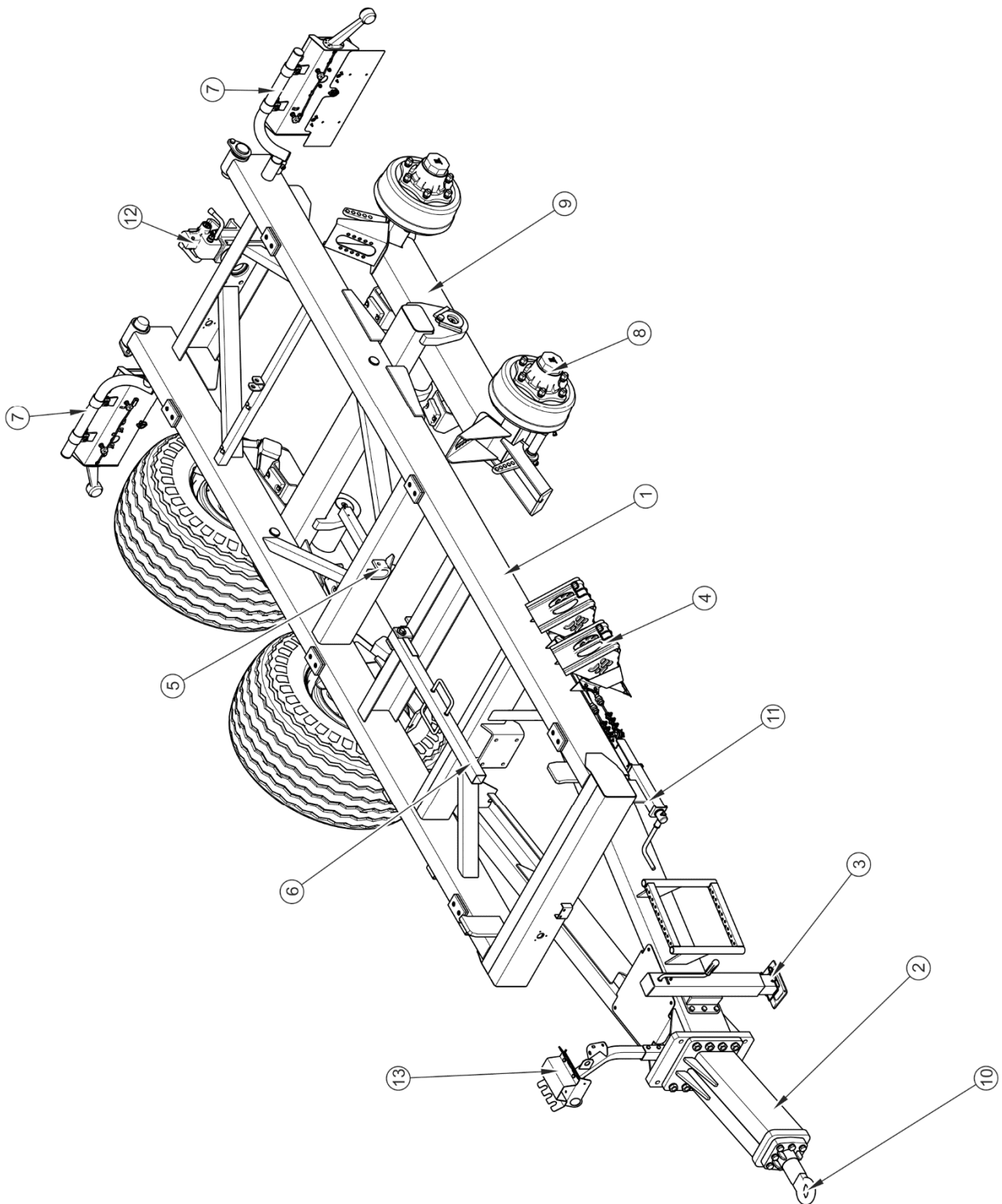

FIGURE 3.1 *Trailer chassis*

(1) lower frame, (2) drawbar, (3) mechanical support, (4) wheel chocks, (5) tipping cylinder socket, (6) load box support, (7) lights support beam, (8) half axle, (9) trailing arm, (10) drawbar hitching eye, (11) parking brake mechanism, (12) rear hitch, (13) conduit bracket

3.2.2 LOAD BOX

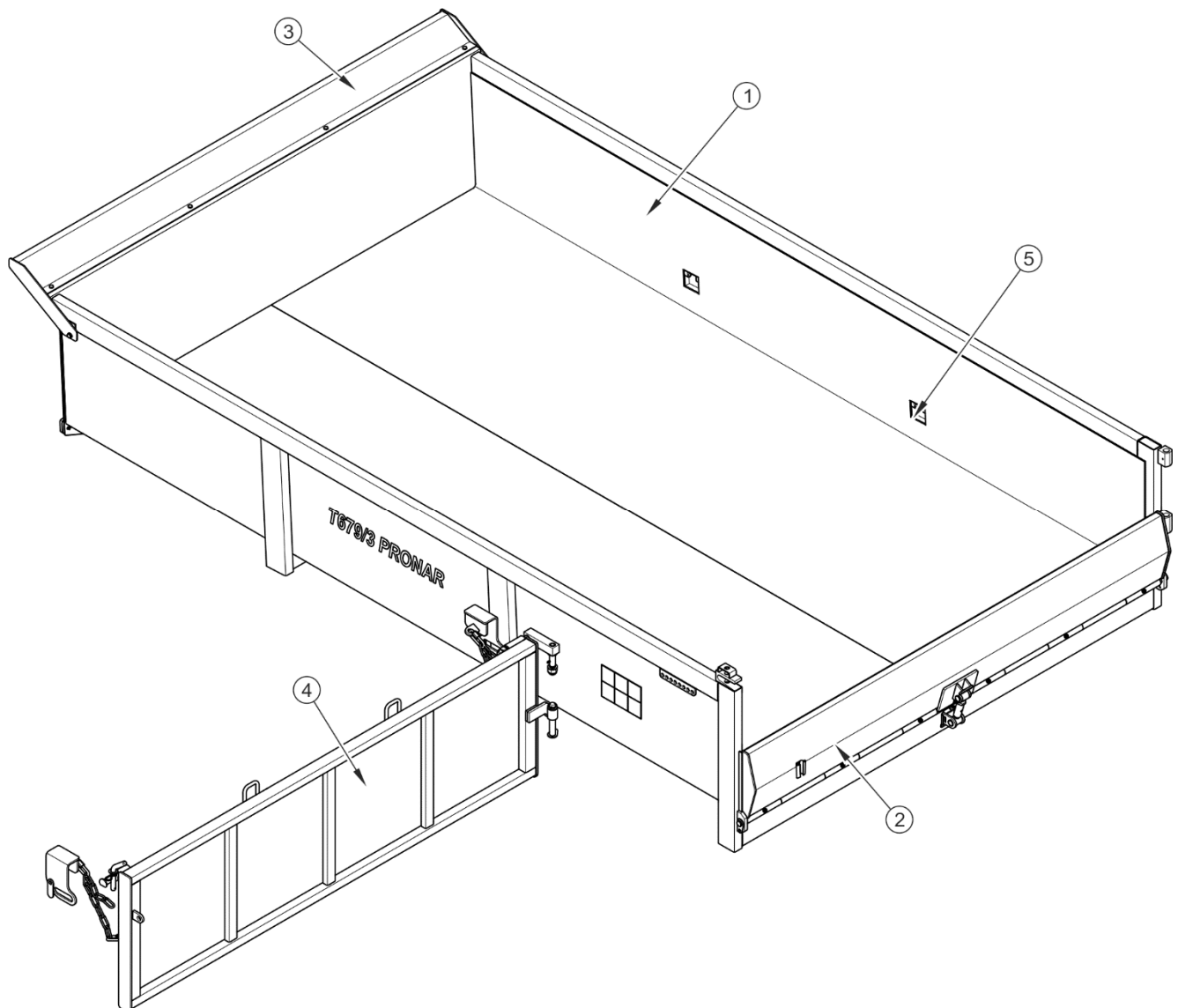

FIGURE 3.2 Load box

(1) load box, (2) hydraulic tailgate, (3) front canopy, (4) hinged-opening tailgate (optional equipment), (5) transport lug

Trailer load box (1) has a monocoque construction. It is made of steel plates and shapes - figure (3.2). In the side walls there are four fixing lugs (5) which ensure reliable fixing of loads. In the rear part of the load box, there is tailgate (2) which is opened and closed using a hydraulic cylinder. The tailgate is opened downwards, which allows easy loading and unloading of construction vehicles. The trailer can be optionally equipped with a hinged-opening tailgate (4), which makes it possible to obtain the desired material layer thickness

when unloading bulk materials. Additionally, the tailgate can be opened to the right side of the trailer to quickly access the trailer load box. Canopy (3), serving as a protective element, is installed in the front part of the load box.

PRONAR offers the load boxes and tailgates made of three different grades of steel in order to meet the customer's expectations. Load box code reflecting the steel grade is stamped on the rear left stake, while tailgate code is stamped on the left tailgate profile. The codes are explained below:

- 235 S235 alloy steel,
- 450 HARDOX 450 steel,

3.2.3 MAIN BRAKE

Depending on the version of the trailer, the machine is equipped with one of two types of service brake:

- ➔ double conduit pneumatic system - figure (3.4).
- ➔ hydraulic braking system, figure - figure (3.5).

The service brake (pneumatic or hydraulic) is activated from the driver's cab by pressing the tractor brake pedal.

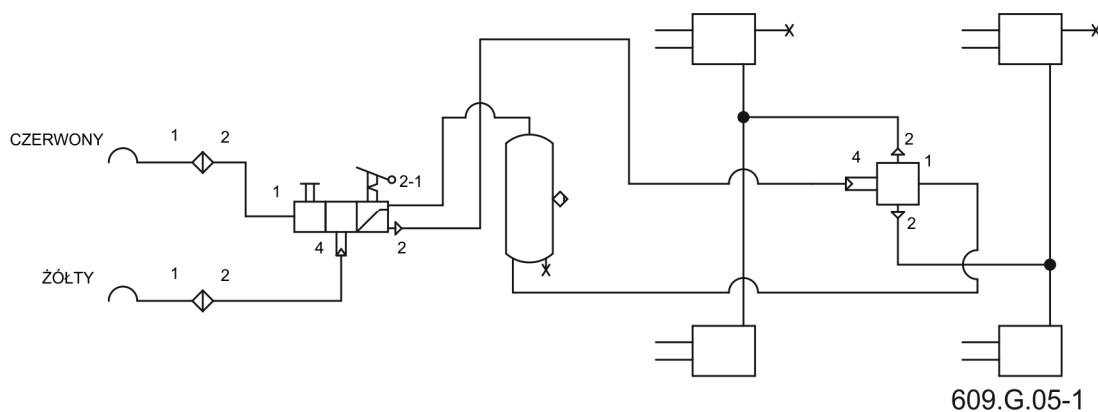

FIGURE 3.3 Diagram of a double conduit pneumatic system



TIP

The hydraulic brake system of the trailer is filled with L-HL32 Lotos hydraulic oil.

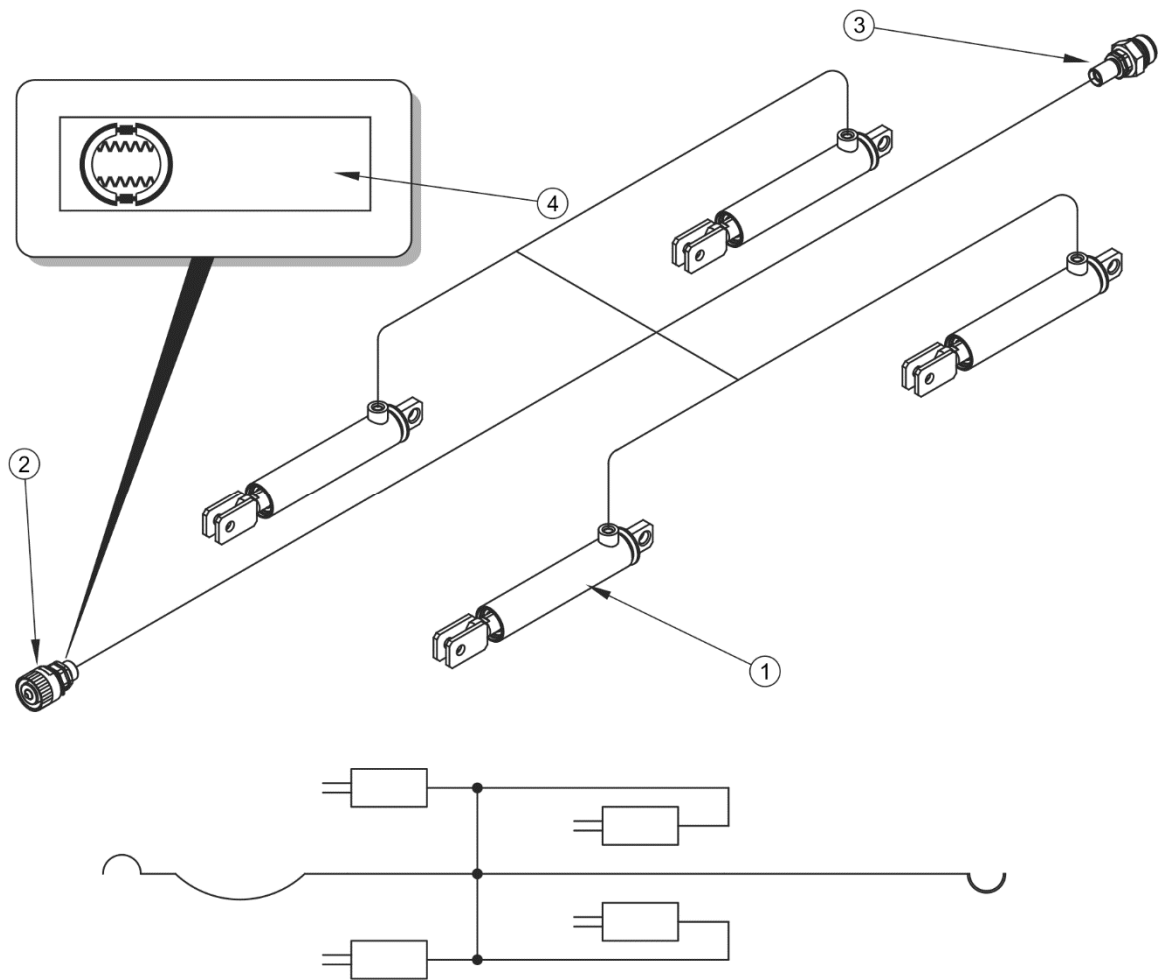
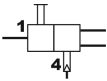









FIGURE 3.4 Design and diagram of hydraulic brake system

(1) hydraulic cylinder, (2) quick coupler socket, (3) plug for the second trailer (option), (4) information decal

TABLE 3.2 List of symbols used in the schemes

SYMBOL	OPIS
	Pneumatic connection, plug
	Pneumatic connection, socket
	Drainage valve

	Main control valve
	Relay valve
	Automatic braking force regulator
	Manual braking force regulator
	Wire connection
	Air tank
	Brake cylinder
	Control valve (connector)
	Air filter

The task of the control valve (1) - figure (3.5),- is to activate the trailer brakes simultaneously with the tractor brake applied. In addition, in the event of an unforeseen disconnection of the hose between the trailer and the tractor, the control valve automatically applies the machine's brake (applies only to pneumatic systems). The valve used has a brake release button (3), used when the trailer is disconnected from the tractor. After connecting the air line to the tractor, the release device automatically adjusts to the position enabling normal operation of the brakes. The three-band braking force regulator - figure (3.5) used in pneumatic systems adjusts the braking force depending on the setting. Switching to the appropriate operating mode is done manually by the machine operator before starting the journey using the lever (4). Three work positions are available:

- ➔ A - "Without load"
- ➔ B - „Half-load"
- ➔ C - „Full load".

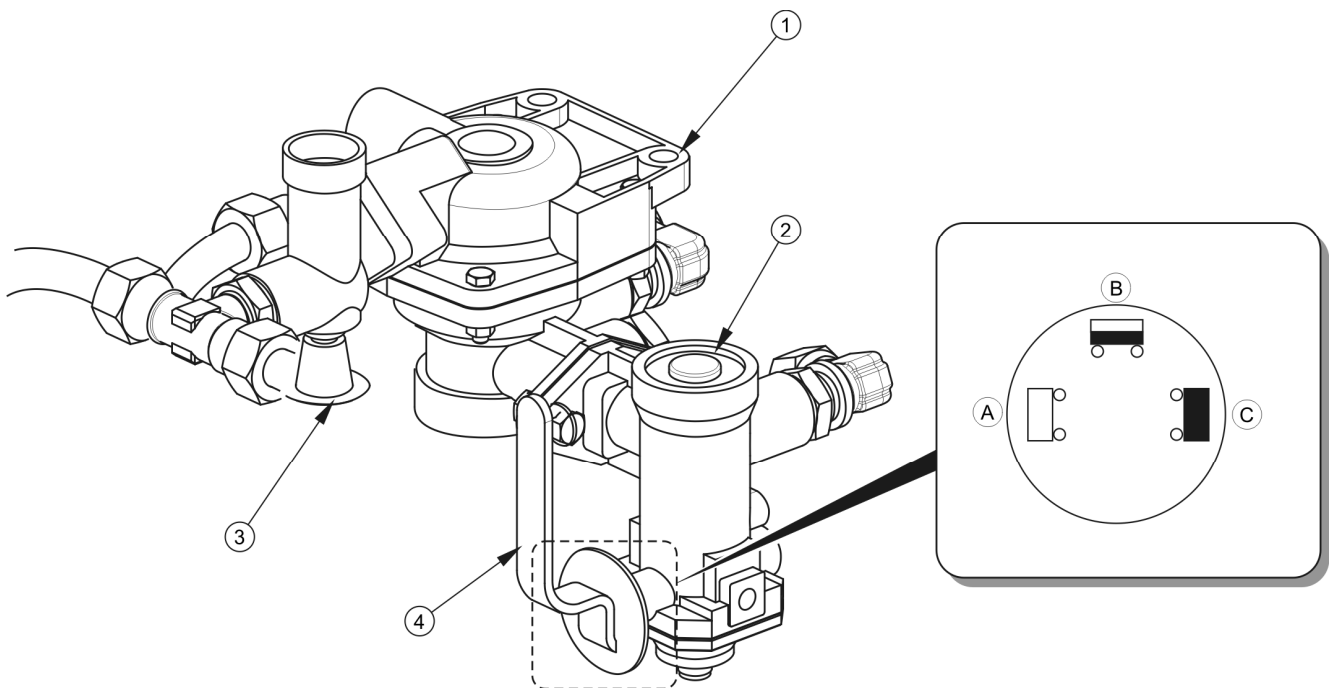

FIGURE 3.5 Control valve and braking force regulator

(1) control valve, (2) braking force regulator, (3) trailer parking brake release button, (4) work selection regulator lever, (A) position "NO LOAD", (B) position "HALF LOAD", (C) position "FULL LOAD"

3.2.4 HYDRAULIC TIPPING SYSTEM

Hydraulic tipping system serves for automatic unloading of trailer by tipping the load box to the rear. The hydraulic tipping system is supplied with oil from the tractor's hydraulic system. Hydraulic oil selective control valve of the tractor's external hydraulic system is used to control the load box tipping mechanism.

The trailer system consists of two independent circuits:

- circuit (A) - to supply the trailer's hydraulic cylinder,
- circuit (B) - to supply the second trailer's hydraulic cylinder (if two trailers are hitched to the tractor).

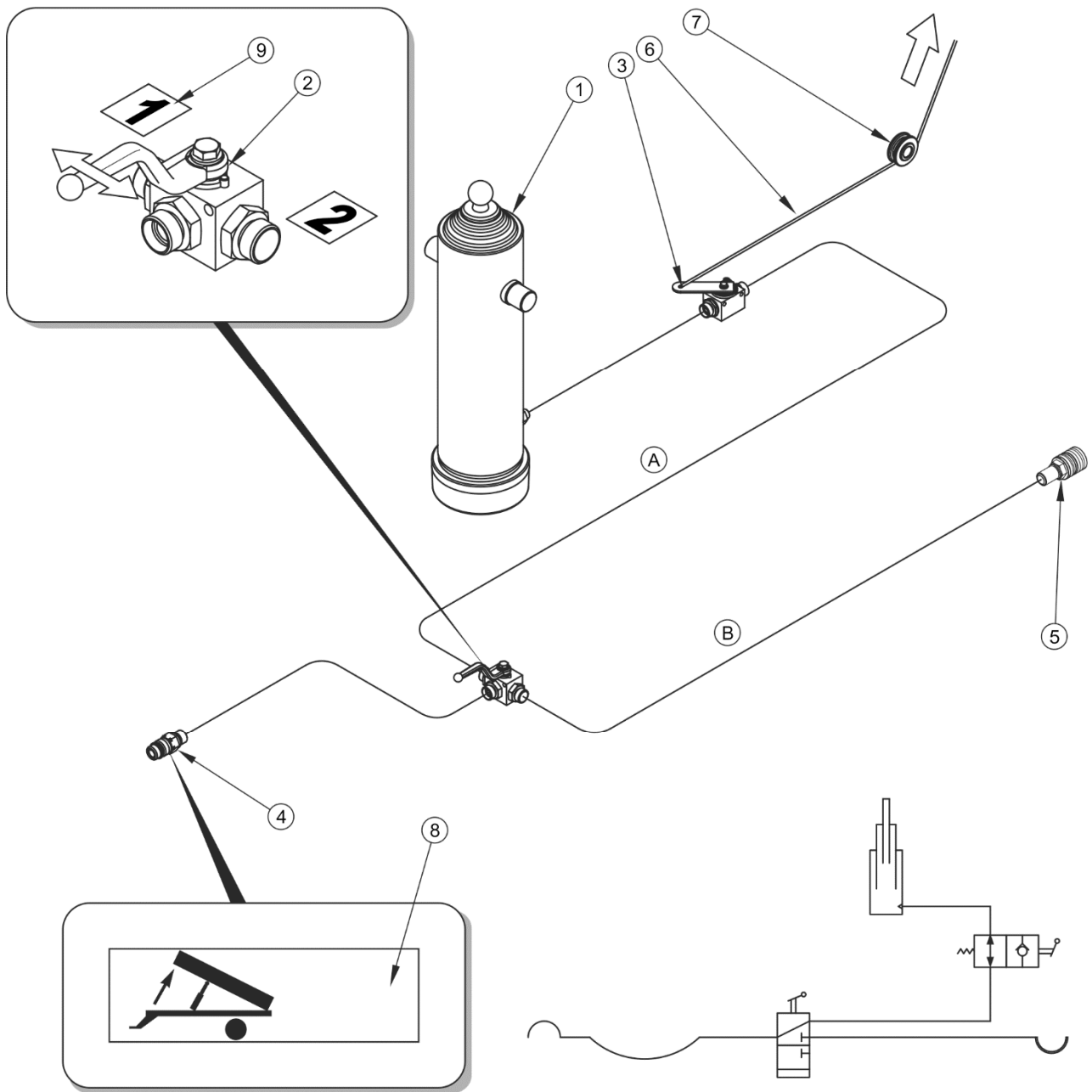

FIGURE 3.6 Hydraulic tipping system design and diagram

(1) telescopic cylinder, (2) three-way valve, (3) cut-off valve, (4) quick coupler, (5) socket, (6) control cable, (7) guide roller, (8), (9) information decal

Three-way valve (2) – figure (3.4) is used to activate these circuits. This valve's lever can be placed in two positions:

- 1 - the trailer's tipping circuit is opened - circuit (A),
- 2 - the second trailer's tipping circuit is opened – circuit (B).

On the connection conduit, in the vicinity of plug (4), there is a decal (8) identifying the supply conduit of the hydraulic tipping system.

ATTENTION



Cut-off valve (3) – figure (3.4) limits the tipping angle of the load box when tipped to the rear. The length of the control cable (6) controlling this valve is factory adjusted by the Manufacturer and must not be changed when the trailer is used.



TIP

The hydraulic system of the trailer is filled with L-HL32 Lotos hydraulic oil.

3.2.5 TAILGATE HYDRAULIC SYSTEM

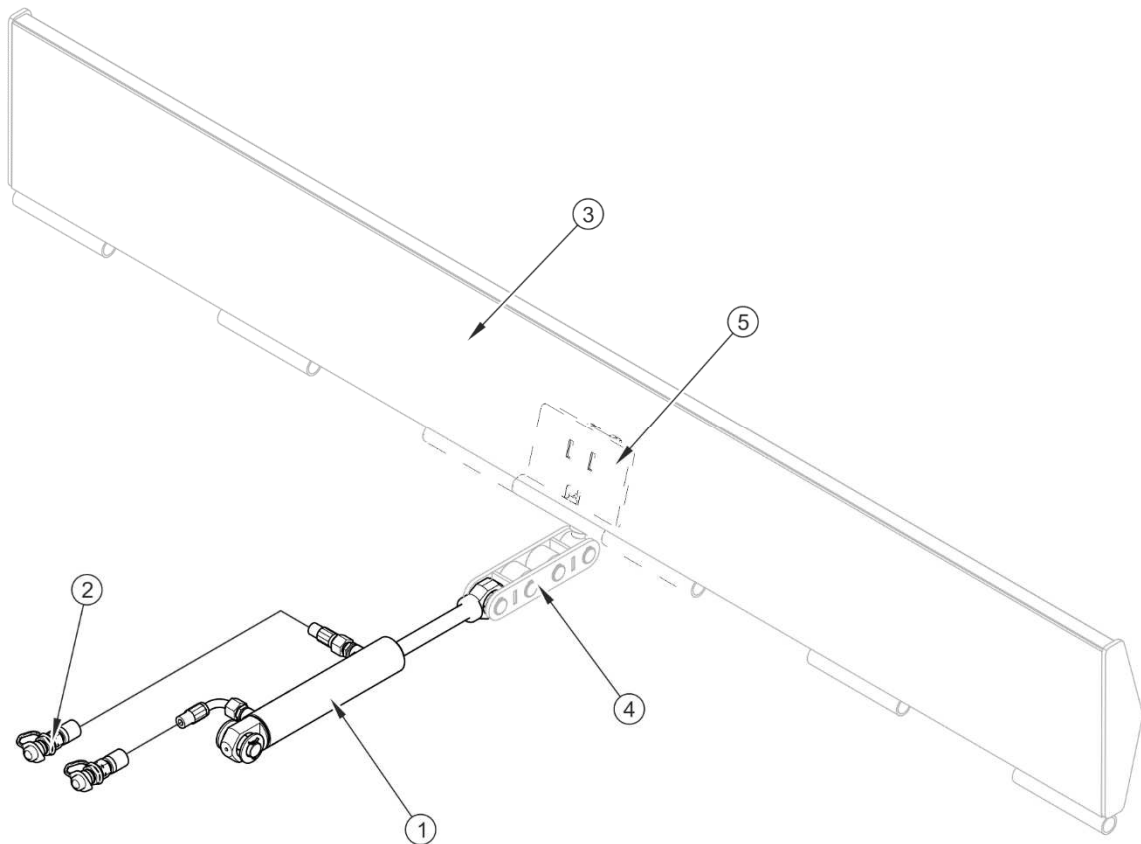

FIGURE 3.7 *Design of the hydraulic system of the tailgate*

(1) hydraulic cylinder, (2) quick coupler, (3) tailgate, (4) slide, (5) clamp

The hydraulic system of the tailgate is used for raising and lowering the tailgate (3). The tailgate can be kept in any position by means of the hydraulics manifold lever. Hydraulic cylinder (1) is connected using conduits terminated with quick couplers (2). Plugs (2) should be placed in proper sockets of the tractor's hydraulic manifold. The system is supplied with oil from the tractor's hydraulic system. Hydraulic oil manifold of the tractor's external hydraulic system is used to control the tailgate rising.

3.2.6 PARKING BRAKE

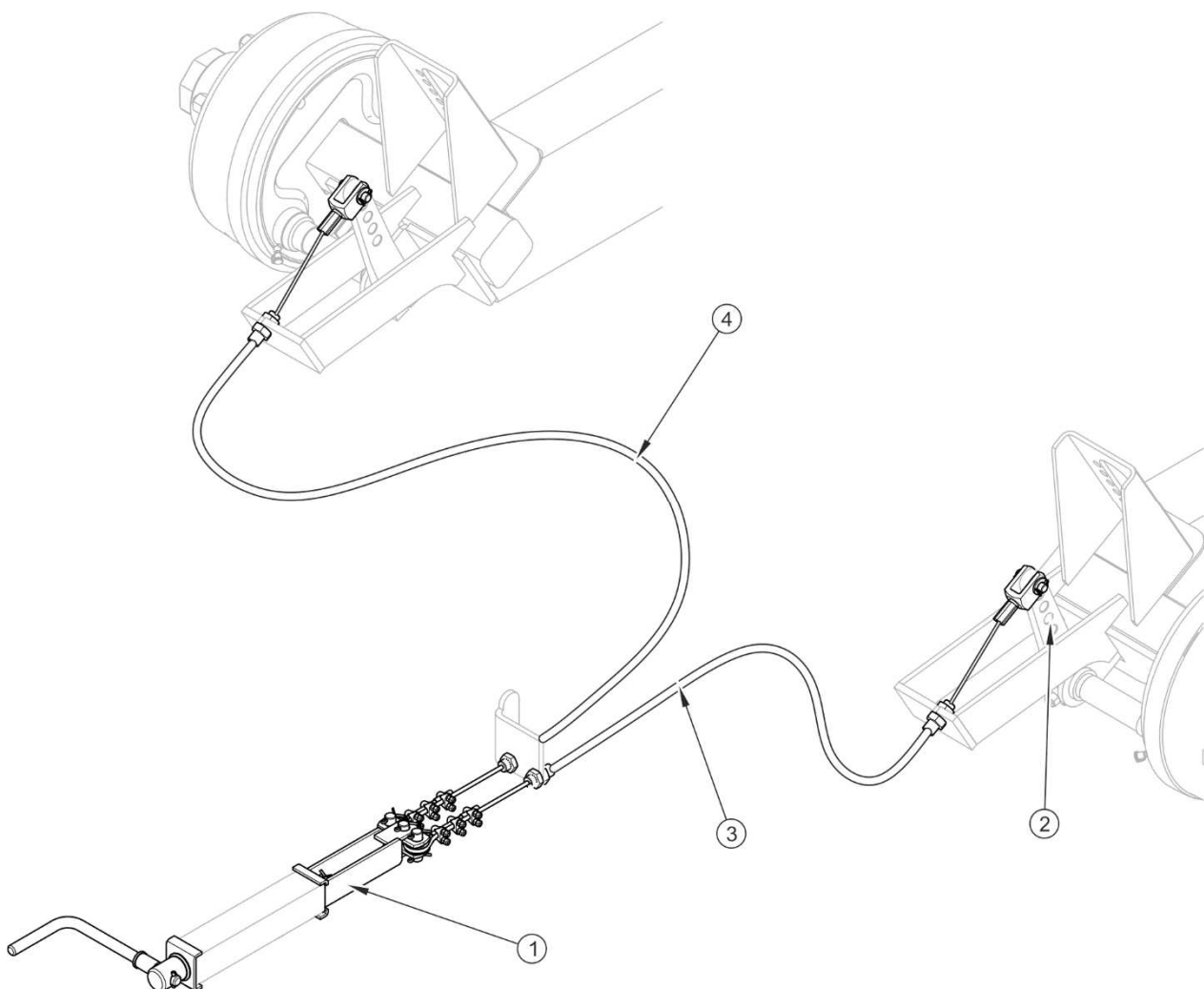

FIGURE 3.8 *Parking brake design*

(1) brake mechanism, (2) expander lever, (3) left cable, (4) right cable

The parking brake is used for immobilising the trailer while standing motionless. Brake crank mechanism (1), located on the left side of the frame, is connected with expander levers (2) of

half axles by means of cables in brake cable conduits (3) and (4). Clockwise rotation of the mechanism crank (1) increases tension of steel cables. Expander arms exert pressure on brake shoes and cause the half axles to brake. Before driving off, parking brake must be released (turn the crank counterclockwise)- steel cables must hang loose and must not exert pressure on expander levers.

3.2.7 ELECTRIC LIGHTING SYSTEM

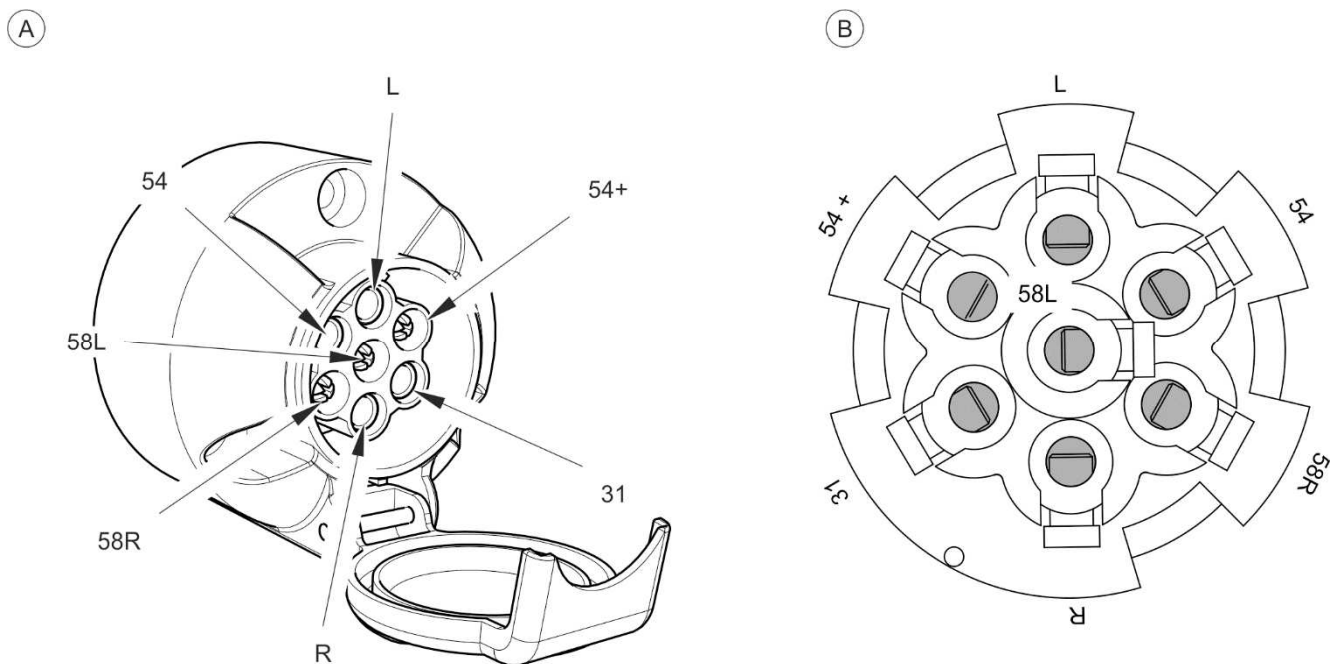

FIGURE 3.9 Connection socket

(A) view of socket, (B) view of socket on the wiring harness fixing side

TABLE 3.3 Marking of connection socket's connections

MARKING	FUNCTION
31	Weight
54+	Power supply +12V
L	Left indicator
54	STOP light
58L	Rear left parking light

MARKING	FUNCTION
58R	Rear right parking light
R	Right indicator

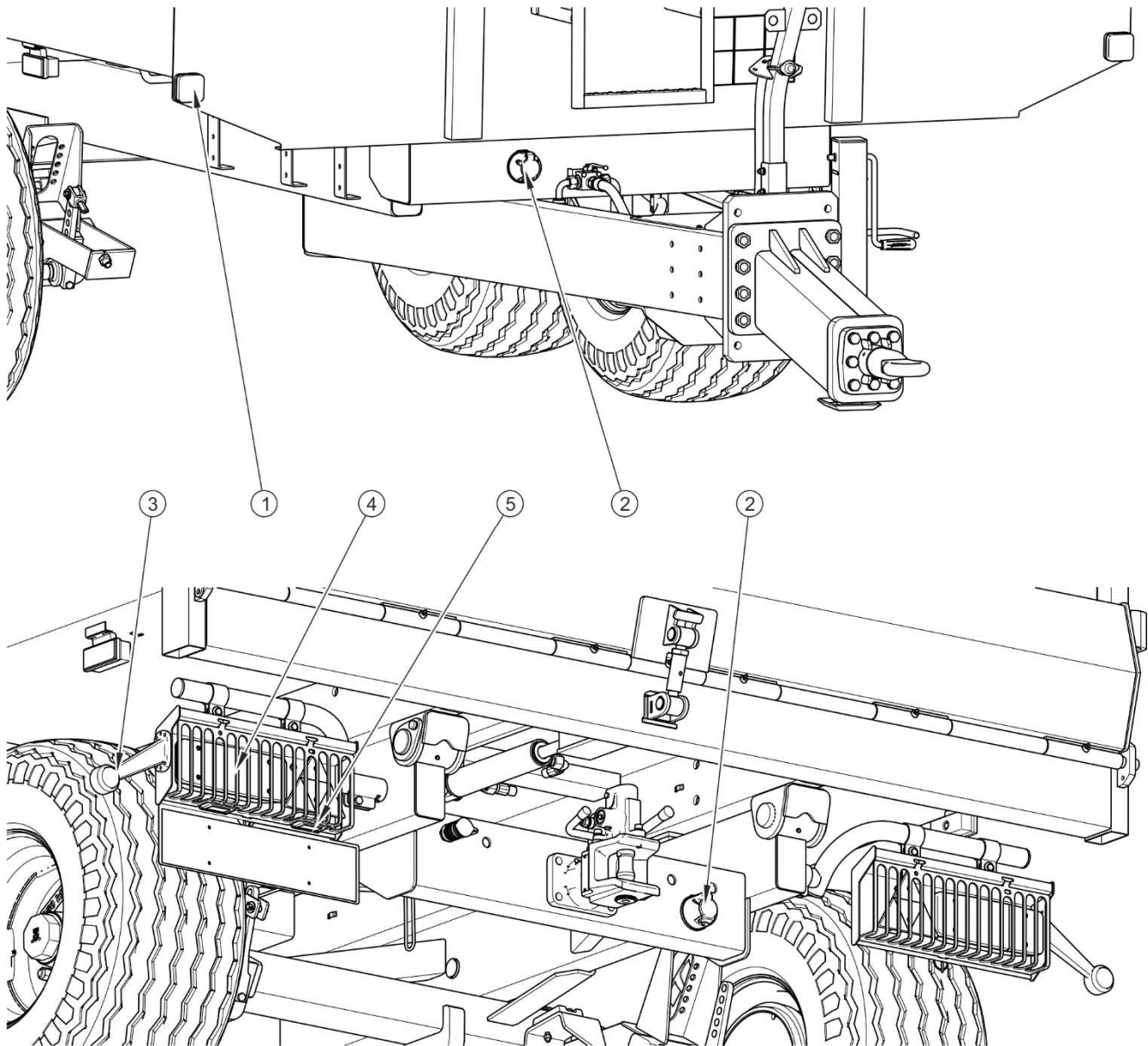

FIGURE 3.10 Arrangement of electrical system components

(1) front parking light, white, (2) 7-pin connection socket, (3) rear clearance light, (4) rear lamp assembly, (5) license plate light

The trailer's electrical system is designed for supplying from direct current source of 12 V. Connection of the trailer's electrical system with the tractor should be made through an appropriate connection lead delivered as standard equipment of the machine.

Arrangement of electrical system components and connection diagram of the connection socket are shown in figures (3.7) and (3.8).

SECTION

4

CORRECT USE

4.1 PREPARING THE TRAILER FOR WORK

4.1.1 PRELIMINARY INFORMATION

The trailer is supplied to the user completely assembled and does not require additional mounting operations of machine sub-assemblies. The manufacturer guarantees that the machine is fully operational and has been checked according to quality control procedures and is ready for use. This does not release the user from an obligation to check the machine's condition prior to purchasing and before first use.

4.1.2 HAND-OVER AND INSPECTION OF THE MACHINE AFTER DELIVERY

After delivery of the machine to the buyer, the user is obliged to check technical condition of the trailer (one-time inspection). While buying the machine, the user must be informed by the seller about the method of use of the machine, risks resulting from the use for purposes other than intended, the method of the machine hitching and the principles of the machine construction and design. Detailed information concerning the machine hand-over are included in the *WARRANTY BOOK*.

Checking the trailer after delivery

- Check completeness of the machine according to order.
- Check technical condition of shields and protection devices.
- Check condition of paint coating; check the machine for traces of corrosion.
- Check the machine for damage resulting from wrong transport of the machine to its destination (crushing, piercing, bending or breaking of minor elements etc.).
- Check air pressure in tyres and check correct tightening of wheel nuts.
- Check technical condition of drawbar eye and if correctly installed.

If non-conformities are found, do not hitch and start using the trailer. Discovered defects should be notified directly to the seller in order to remove them.

**ATTENTION**

The seller is obliged to conduct the first start up of the trailer in the presence of the user.

The user trained by the seller is not released from the obligation to read this Operator's Manual carefully.

4.1.3 PREPARING THE TRAILER FOR THE FIRST USE, TEST RUN OF THE TRAILER

**TIP**

All maintenance activities concerning the trailer are described in detail in further sections of the Operator's Manual.

Preparing for the test run

- The user must read this *OPERATOR'S MANUAL* and observe all the recommendations contained in it.
- Adapt the height of the trailer drawbar to the tractor hitch.
- Visually inspect the trailer according to the guidelines presented in section *PREPARING THE TRAILER FOR NORMAL USE*.
- Hitch machine to tractor. Immobilise tractor with parking brake.

Test start

- Check all the trailer's lubrication points, lubricate the machine as needed according to recommendations provided in section 5,
- Check if the nuts and bolts fixing the wheels are properly tightened.
- Drain air tank of the pneumatic brake system.
- Ensure that hydraulic, pneumatic and electric connections in agricultural tractor are according to the requirements. Otherwise, the trailer should not be hitched to the tractor.
- Hitch trailer to tractor.

- Switch on individual lights, check correct operation of electrical system.
- Release tractor's parking brake. Perform test drive. Check the trailer's braking efficiency during driving.
- Stop tractor and turn off the engine, immobilise the tractor and trailer with parking brake.

If during test run worrying symptoms occur such as:

- excessive noise and abnormal sounds originating from the rubbing of moving elements,
- leaky brake system, hydraulic oil leaks,
- incorrect operation of brake cylinders,
- other faults,

stop operating the trailer and do not operate it until the malfunction is corrected. If a fault cannot be rectified or the repair could void the warranty, please contact retailer for additional clarifications or to perform the repair.

4.1.4 PREPARING THE TRAILER FOR NORMAL USE

DANGER



Careless and improper use and operation of the trailer, and non-compliance with the recommendations given in this operator's manual is dangerous to your health.

The machine must never be used by persons, who are not authorised to drive agricultural tractors, including children and people under the influence of alcohol or other drugs.

Non-compliance with the safety rules of this Operator's Manual can be dangerous to the health and life of the operator and others.

Scope of inspection activities

- Visually inspect if the tyres are properly inflated. In case of doubt, carefully check tyre pressure.
- Check technical condition of drawbar eye.

- Check correctness of electrical system operation.
- Check technical condition and completeness of shields and protection devices.
- Install the slow-moving vehicle warning sign - if the trailer is used on public roads.

4.2 HITCHING AND UNHITCHING THE TRAILER

Ensure that all connections (electric and hydraulic connections) and the hitch of agricultural tractor are according to the Manufacturer's requirements. Otherwise, the trailer should not be hitched to the tractor. In order to hitch the trailer to the tractor perform the actions below in the sequence presented.

Hitching to tractor

- ➔ Position agricultural tractor directly in front of the trailer's drawbar eye.
- ➔ Reverse tractor, hitch trailer to appropriate hitch on tractor, check hitch lock protecting machine against accidental unhitching.
- ➔ If the agricultural tractor is equipped with an automatic coupler, ensure that the hitching operation is completed and that drawbar eye is secured.
- ➔ Turn off tractor engine. Ensure that unauthorised persons do not have access to the tractor cab.
- ➔ Connect the braking system conduits.
 - ⇒ If the trailer is equipped with a double conduit pneumatic system, first connect the yellow pneumatic conduit to the yellow socket in the tractor and then connect the red conduit to the red socket in the tractor.
 - ⇒ If the trailer is equipped with a single conduit pneumatic system, connect the black pneumatic conduit to the black socket in the tractor.
 - ⇒ If the trailer is equipped with hydraulic braking system, insert hydraulic conduit plug into proper braking system socket in the agricultural tractor.
- ➔ Connect the electrical lighting system lead.

- ➔ Check and, if necessary, protect leads against abrasion or other mechanical damage.
- ➔ Just before driving off, raise the mechanical support, remove chocks from under the trailer's wheels and release parking brake.

When turning, connecting conduits must hang loosely and not become tangled with moving elements of machine and tractor.

DANGER



When hitching, there must be nobody between the trailer and the tractor. When hitching the machine, tractor driver must exercise particular caution and make sure that nobody is present in the hazard zone.

When connecting the hydraulic or pneumatic conduits to the tractor, make sure that the hydraulic and pneumatic systems of the tractor and the trailer are not under pressure.

Ensure sufficient visibility during hitching.

After completion of hitching check the security of the hitching pin.

Exercise caution when unhitching the trailer from the tractor. Ensure good visibility. Unless it is necessary, do not go between tractor and machine.

Before disconnecting conduits and drawbar eye, close tractor cab and secure it against access by unauthorised persons. Turn off tractor engine.

The trailer must not be disconnected when loaded.



ATTENTION

The trailer must not be used when not in working order.

Unhitching

In order to disconnect the trailer from the tractor follow these steps.

- ➔ Immobilise tractor with parking brake, turn off tractor engine
- ➔ Ensure that unauthorised persons do not have access to the tractor cab.
- ➔ Place chocks under the trailer's wheels in order to prevent the machine from rolling.
- ➔ Unfold the trailer's mechanical support.
- ➔ Disconnect electric lead.
- ➔ Disconnect braking system conduits.
 - ⇒ If the trailer is equipped with a double conduit pneumatic system, first disconnect the red conduit and then disconnect the yellow conduit.
 - ⇒ If the trailer is equipped with a single conduit pneumatic system, first disconnect the black conduit.
 - ⇒ Disconnect hydraulic conduit of the hydraulic braking system from the section of the manifold of the tractor's external hydraulic system.
- ➔ Protect conduit ends with covers. Place conduit plugs in appropriate sockets.
- ➔ Release tractor hitch, drive tractor away from the trailer.

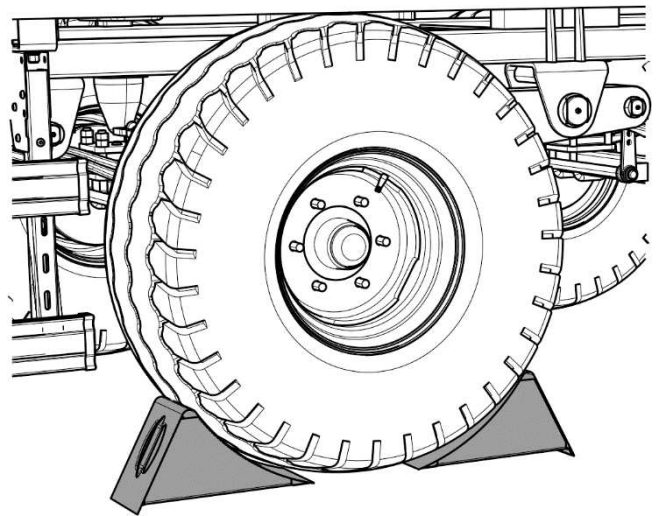

FIGURE 4.1 *Proper position of chocks*

4.2.1 HITCHING AND UNHITCHING THE SECOND TRAILER

A second trailer may only be hitched if it is a machine built on a dual axle chassis and if it fulfils all the requirements specified in section 1. Hitching the second trailer to the tractor - trailer unit requires experience in driving an agricultural tractor. While hitching the second trailer, it is recommended to use the help of another person to guide the tractor driver.

Hitching the second trailer

- ➔ Position the tractor with the first trailer hitched directly in front of the second trailer's drawbar.
- ➔ Immobilise second trailer with parking brake.
- ➔ Remove pin from the rear hitch of the first trailer.
 - ⇒ If the trailer is fitted with automatic rear hitch, lift the pin by the handle.
- ➔ Adjust the height of the drawbar of the second trailer in such a manner to enable coupling the machines.
- ➔ Reversing tractor, drive the rear hitch of the first trailer onto the drawbar of the second trailer.
 - ⇒ If the trailer is is equipped with an automatic rear hitch, ensure that the hitching operation is completed and that drawbar eye of the second trailer is secured.
- ➔ Insert drawbar pin and securing cotter pin.

Connect conduits of hydraulic system and pneumatic system and electrical leads according to instructions contained in section (4.2).



DANGER

When hitching, there must be nobody between the trailers. Person assisting in hitching the machines should stand outside the area of danger and be visible to the tractor driver at all times.

Unhitching the second trailer

- ➔ Immobilise tractor and trailer with parking brake.
- ➔ Turn off tractor engine. Ensure that unauthorised persons do not have access to the tractor cab.
- ➔ Connect conduits of hydraulic system and pneumatic system and electrical leads according to instructions contained in section (4.2).
 - ⇒ If the trailer is fitted with automatic rear hitch, lift the pin by the handle.

- ➔ Unlock the pin of the hitch of the first trailer. Remove the pin and drive tractor away.

**DANGER**

Only double axle trailers may be hitched to the trailer.

4.3 LOADING AND SECURING LOAD

4.3.1 GENERAL INFORMATION ABOUT LOADING

**DANGER**

Overloading the trailer, erroneous loading and securing of the load is the most frequent cause of accidents during transport.

Uneven arrangement of the load may cause overloading of the trailer's axle.

People or animals must not be carried on the trailer.

During work, keep a safe distance from overhead electric power lines.

When loading or unloading the trailer, bystanders must exercise caution and keep a safe distance from danger zones.

The trailer is designed for transporting and unloading heavy materials such as: debris, stones, rubble, gravel, used during construction, the earthworks, demolition, on the farm and on public roads. Load box design enables loading and transportation of machinery and construction vehicles.

The trailer must be positioned to travel forwards and be hitched to the tractor. Loading should only take place, when trailer is placed on flat level surface and hitched to tractor. Before loading, check technical condition of the tailgate and ensure that it is correctly secured. Check technical condition of hydraulic and pneumatic systems. Pay particular attention to the brake cylinder leaks. Do NOT load or drive the trailer with damaged tailgate system, braking system or hydraulic tipping system. It is recommended to unload the trailer using a loader, conveyor or forklift truck. Keep a safe distance during loading and unloading. Do not allow anyone to approach the place where works are carried out.

Load should be uniformly distributed along the length and width of the load box in order to ensure proper distribution of half axle loads and proper stability of the trailer. Load must not extend beyond the outline of the load box. The permissible loading height defined by the road traffic regulations and permissible design load of the trailer must not be exceeded. When loading goods on pallets, pay special attention to their arrangement on the load box. Pallets must be secured against the displacement on the platform. Pallets must not be stacked in layers. Secure the load using fixing lugs located in the load box.

ATTENTION



Do NOT exceed the trailer's maximum carrying capacity.

Load placed on the load platform must be uniformly distributed and properly secured.

Transported machines should be secured against movement, using appropriate belts in good condition, which are attached to transport lugs.

When driving on public roads, the hydraulic tailgate or hinged-opening tailgate must be folded.

The load must be arranged in such a way that it does not threaten the stability of the trailer and does not hinder driving.

Loading should be carried out by a person having appropriate authorisation for operating the equipment (if required).

4.3.2 SECURING LOAD

Load (crushed stone, construction machines, pallets or pallet boxes) should be adequately protected against moving by means of belts with a tightening mechanism. The belts may be attached to the following structural elements:

- transport lugs inside the load box,
- transport lugs welded to the load box cross-bars,

The extent of protection depends on loading method, type of load and size of load. If load is to be transported on slopes and/or in strong gusty winds conditions, limit the load height according to existing conditions.

Regardless of the type of load carried, the user is obliged to secure it in such a manner that the load is unable to spread and cause contamination of the road.

It is impossible to describe all methods of loading due to the diversity of materials, tools, means of fixing and securing a load. While working be guided by caution and own experience. The trailer user must carefully read the regulations concerning road transport and comply with them.

Due to the various density of materials, using the total load box capacity may cause exceeding permissible carrying capacity of the trailer. Guideline specific weight of selected materials is shown in table (4.1). Take care not to overload the trailer.

TABLE 4.1 *Guideline weights by volume of selected loads*

TYPE OF MATERIAL	WEIGHT BY VOLUME KG/M ³
Building materials:	
cement	1,200 – 1,300
dry sand	1,350 – 1,650
wet sand	1,700 – 2,050
solid bricks	1,500 – 2,100
hollow bricks	1,000 – 1,200
stones	1,500 – 2,200
soft wood	300 - 450
hard sawn timber	500 - 600
impregnated timber	600 - 800
steel structures	700 – 7,000
milled burnt lime	700 - 800
cinders	650 - 750
gravel	1,600 – 1,800
rubble	1,050 – 1,200
Root crops:	
raw potatoes	700 - 820
steamed crushed potatoes	850 - 950
dried potatoes	130 - 150
sugar beet - roots	560 - 720
fodder beet – roots	500 - 700

TYPE OF MATERIAL	WEIGHT BY VOLUME KG/M ³
Mineral fertilisers: ammonium sulphate potash salt super phosphate basic slag phosphate potassium sulphate milled lime fertiliser	800 - 850 1,100 – 1,200 850 – 1,440 2,000 – 2,300 1,200 – 1,300 1,250 - 1,300
Concentrated feeds and mixed feeds: stored chaff pressed cake milled dry feed mixed feeds mineral mixtures ground oats wet sugar beet pulp pressed sugar beet pulp dry sugar beet pulp bran bone meal pasture salt molasses silage (pit silo) hay silage (tower silo)	200 - 225 880 – 1,000 170 - 185 450 - 650 1,100 – 1,300 380 - 410 830 - 1,000 750 - 800 350 - 400 320 - 600 700 – 1,000 1,100 – 1,200 1,350 – 1,450 650 – 1,050 550 - 750
Seeds and grains: beans mustard peas lentils runner beans barley clover grass	750 - 850 600 - 700 650 - 750 750 - 860 780 - 870 600 - 750 700 - 800 360 - 500

TYPE OF MATERIAL	WEIGHT BY VOLUME KG/M ³
maize	700 - 850
wheat	720 - 830
oil seed rape	600 - 750
linseed	640 - 750
lupins	700 - 800
oats	400 - 530
lucerne	760 - 800
rye	640 - 760
Others:	
dry soil	1,300 – 1,400
wet soil	1,900 – 2,100
fresh peat	700 - 850
garden soil	250 - 350

Source: "Technology of machine work in agriculture", PWN, Warszawa 1985

4.4 TRANSPORTING LOADS

When driving on public roads, respect the road traffic regulations, exercise caution and prudence. Listed below are the key guidelines for driving the tractor and trailer combination.

- Before moving off make sure that there are no bystanders, especially children, near the trailer or the tractor. Take care that the driver has sufficient visibility.
- Make sure that the trailer is correctly attached to the tractor and tractor's hitch is properly secured.
- Vertical load borne by the trailer drawbar eye affects the steering of the agricultural tractor.
- The trailer must not be overloaded, loads must be uniformly distributed so that the maximum permissible axle loads are not exceeded. The trailer's maximum carrying capacity must not be exceeded as this can damage the trailer and pose a risk to the operator or other road users.

- Permissible design speed and maximum speed allowed by road traffic law must not be exceeded. The towing speed should be adapted to the current road conditions, load carried by the trailer, road surface conditions and other relevant conditions.
- When not connected to the tractor, the trailer must be immobilised using parking brake and with chocks placed under the wheels. Do NOT leave unsecured trailer. In the event of machine malfunction, pull over on the hard shoulder avoiding any risk to other road users and position reflective warning triangle according to traffic regulations.
- When driving on public roads, the trailer must be marked with a slow-moving vehicle warning sign attached to the rear wall of load box, if the trailer is the last vehicle in the group.
- While driving on public roads the trailer must be fitted with a certified or authorised reflective warning triangle.
- When driving, comply with all road traffic regulations, indicate an intention to turn using indicator lamps, keep all road lights and indicator lights clean at all times and ensure they are in good condition. Any damaged or lost lamps or indicator lights must be immediately repaired or replaced.
- Avoid ruts, depressions, ditches or driving on roadside slopes. Driving across such obstacles could cause the trailer or the tractor to suddenly tilt. This is of special importance because loaded trailer's centre of gravity is higher (especially a high volume load), which reduces safety. Driving near ditches or channels is dangerous as there is a risk of the wheels sliding down the slope or the slope collapsing.

**ATTENTION**

Travel with a high-volume load by ruts, ditches, roadside slopes etc. constitutes a great risk of overturning the trailer. Exercise particular caution.

- Speed must be sufficiently reduced before making a turn or driving on an uneven road or a slope.
- When driving, avoid sharp turns especially on slopes.

- While driving on public roads, the tailgate must be closed.
- Please note that the braking distance of the tractor and trailer combination is substantially increased at higher speeds and loads.
- Monitor trailer's behaviour when travelling on an uneven terrain, and adjust driving speed to road conditions, slow down early enough when turning.
- Prolonged driving across steep ground may lead to loss of braking efficiency.
- The trailer is designed to operate on slopes up to 8°. Driving trailer across ground with steeper slopes may cause the trailer to tip over as a result of loss of stability. Prolonged driving across steep ground may lead to loss of braking efficiency.

4.5 UNLOADING

The trailer is equipped with hydraulic tipping system and suitable frame structure and the load box allowing tipping to the rear. Tipping of the load box is controlled from driver's cab using external tractor hydraulic system selective control valve.

The trailer must be positioned to travel forwards and be hitched to the tractor. Unloading should only take place when the trailer is placed on flat level surface and hitched to tractor.



DANGER

*Ensure that during unloading nobody is in the vicinity of the unloading zone.
During work, keep a safe distance from overhead electric power lines.*

Goods on pallets and bulk materials should be unloaded from the trailer using a loader, conveyor or forklift truck. During work, ensure good visibility and exercise particular caution. Immobilise tractor and trailer with parking brake. Just before unloading, remove all securing elements (belts, ropes, etc.). Unloading the trailer should be carried out in accordance with the general principles of workplace health and safety.

Unloading trailer is performed in the following sequence:

- ➔ tractor and trailer must be placed to drive forwards on flat and hard ground,
- ➔ immobilise tractor with parking brake,

- open hydraulic tailgate (1) (standard) - Figure (4.2), using the cylinder by operating a lever on the tractor hydraulic manifold,
 - ⇒ when unloading the load box equipped with hinged hatch (1) set the width of the slot opening using chain catches (5), which should be secured by means of pin (6) and cotter pin (7) – figure (4.3). If necessary, the slot size can be adjusted by changing the length of chains (4),

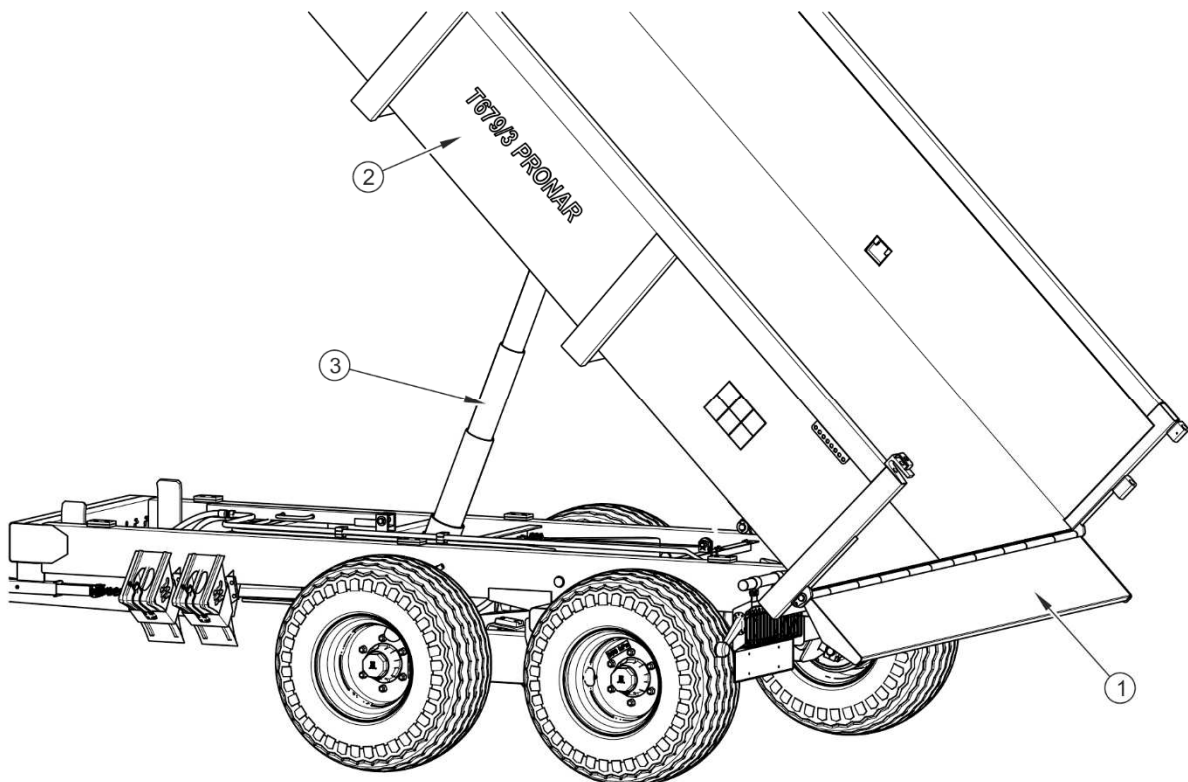

FIGURE 4.2 *Unloading load box with hydraulic tailgate*

(1) hydraulic tailgate, (2) load box, (3) telescopic cylinder

- place the control lever of the hydraulic tipping system circuits in position 1 -- tipping of the first trailer,
- using the manifold lever in the operator cab tip the load box with a telescopic cylinder (3),
- after unloading, lower the load box and clean the floor edges,

- ➔ close the hydraulic tailgate (1) by actuating a suitable hydraulic circuit from the tractor - figure (4.2),
 - ⇒ load box with hinged hatch (1) must be secured with chain catches (5) - Figure (4.3),
- ➔ before moving off make sure that the hydraulic tailgate or hinged hatch is properly locked.

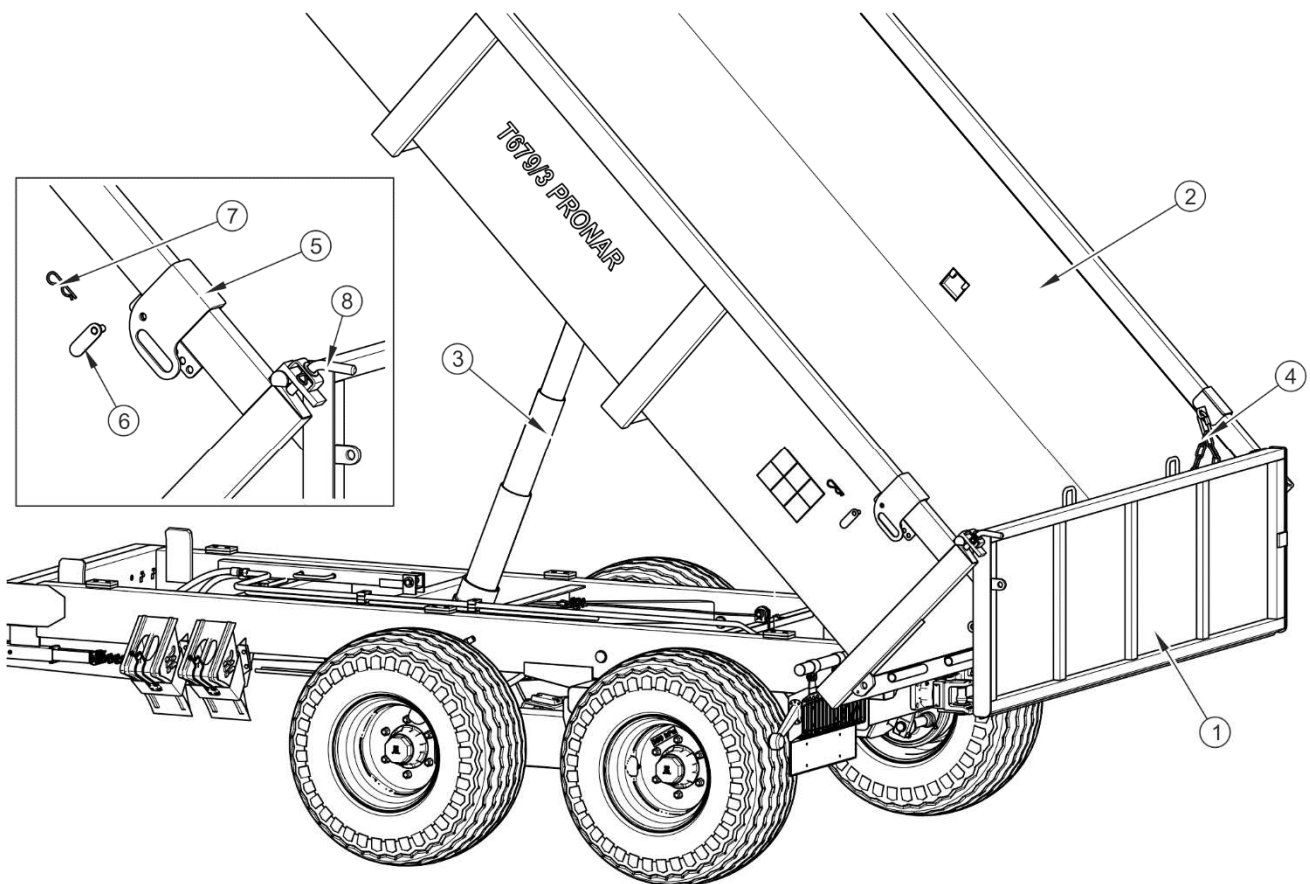

FIGURE 4.3 *Unloading load box with hinged-opening tailgate*

(1) hydraulic tailgate, (2) load box, (3) telescopic cylinder, (4) chain, (5) chain catch, left, (6) catch pin, (7) cotter pin, (8) pin

In case of the trailer with hinged-opening tailgate, construction materials and construction equipment can be loaded and unloaded by opening the hatch (1) to the right side of the trailer. To do this, remove pin (8) together with securing cotter pin and open the hatch. It is permissible to unload the load box with open hatch to the side provided that the hatch is secured with pin (8) in the load box holder. The load box with the hatch open to the side may

be loaded and unloaded only if the load box is completely lowered. Do NOT pull pin (8) out when the load box is raised.

ATTENTION



Do NOT jerk the trailer forwards if load is bulky or reluctant to pour and does not unload.

Do NOT move off or drive when load box is raised.

Do not unload the trailer when the second trailer is connected.

Do NOT tip load box in strong gusty winds conditions.

Tipping the load box must be done on hard and level ground.

Tipping may only be performed when trailer is hitched to tractor.

4.6 PROPER USE AND MAINTENANCE OF TYRES

When working with tyres, the trailer should be secured against rolling by placing chocks under the wheels. Wheels can be taken off the trailer axle only when the trailer is not loaded.

- Repair work on the wheels or tyres should be carried out by persons trained and entitled to do so. This work should be carried out using appropriate tools.
- Inspect tightness of wheel nuts after the first use of the trailer, every 2 - 3 hours during the first month of work and then every 30 hours of use (travel). The inspection should be repeated individually if a wheel has been removed from the wheel axle. Wheel nuts should be tightened according to recommendations provided in section 5 MAINTENANCE.
- Regularly check and maintain correct air pressure in tyres according to Operator's Manual (especially if trailer is not used for a longer period).
- Pressure and tyres should be also checked during the whole day of intensive work. Please note that higher temperatures could raise tyre pressure by as much as 1 bar. At high temperatures and pressure, reduce load or speed.
- Do not release air from warm tyres to adjust the pressure or the tyres will be underinflated when temperatures return to normal.
- Tyre valves should be protected with the appropriate caps to avoid soiling.

- Do not exceed the trailer's maximum design speed.
- When the trailer is operated all day, stop working for a minimum of one hour in the afternoon.
- Adhere to 30 minutes rest for cooling tyres after driving 75 km or after 150 minutes continuous travel depending on which occurs first.
- Avoid potholes, sudden manoeuvres or high speeds when turning.

SECTION

5

MAINTENANCE

5.1 PRELIMINARY INFORMATION

When using the trailer, regular inspections of its technical condition and the performance of maintenance procedures are essential, which keep the machine in good technical condition. In connection with this the user of the trailer is obliged to perform all the maintenance and adjustment procedures defined by the Manufacturer.



ATTENTION

Repairs during the warranty period may only be performed by authorised service points.

Detailed procedures and extent of activities which the user may perform by himself are described in this section. In the event of unauthorised repairs, changes to factory settings and other actions, which are not regarded as possible for the trailer operator to perform, the user shall invalidate the warranty.

5.2 MAINTENANCE OF WHEEL AXLE

5.2.1 PRELIMINARY INFORMATION

Work connected with the repair, change or regeneration of axle components should be entrusted to specialist establishments, having the appropriate technology and qualifications for this type of work.

The responsibilities of the user are limited to:

- inspection and adjustment of slackness of axle bearings,
- mounting and dismounting wheel, inspection of wheel tightening,
- checking and maintaining proper air pressure in tyres, evaluating technical condition of wheels and tyres,
- checking thickness of brake shoe linings,
- mechanical brakes adjustment,

Procedures connected with:

- changing grease in axle bearings,
- changing bearings, hub seals,
- replacement of brake shoes,
- other axle repairs,

may be performed by specialized vehicle service stations.

5.2.2 CHECKING SLACKNESS OF WHEEL AXLE BEARINGS

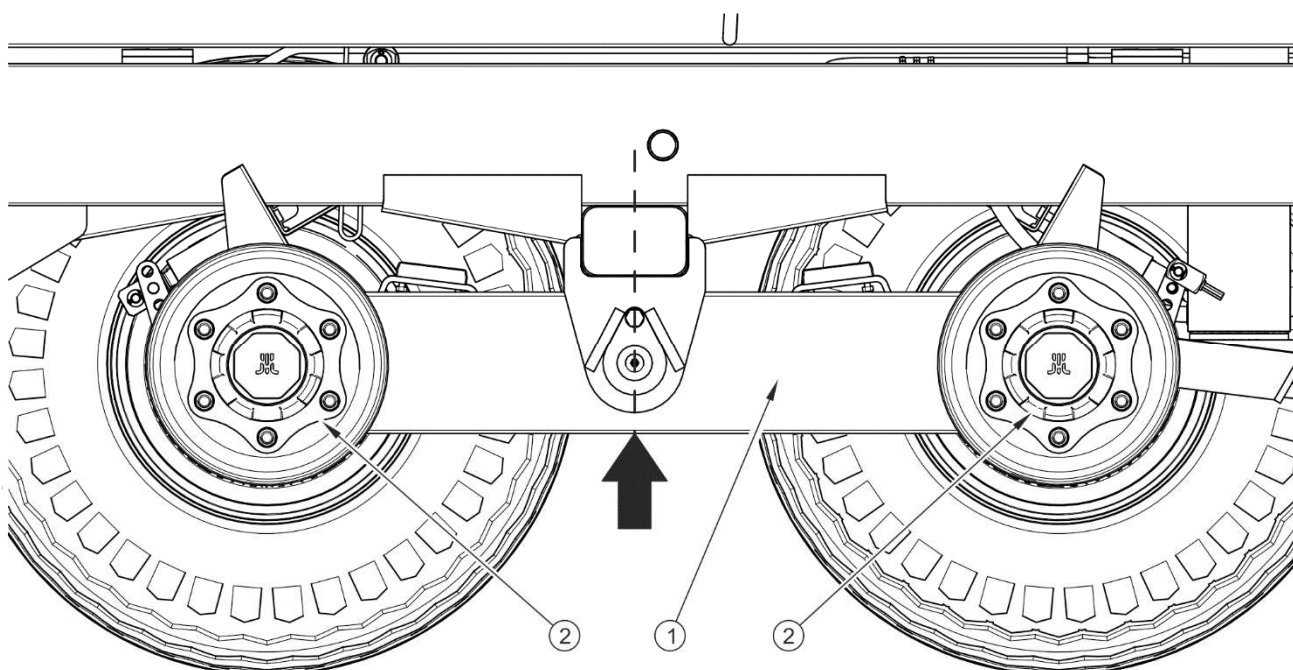

FIGURE 5.1 *Lifting jack support point*

(1) suspension system rocker, (2) half axle

Preparation procedures

- ➔ Hitch trailer to tractor, immobilize tractor with parking brake.
- ➔ Park the trailer on hard level ground.
 - ⇒ Tractor must be placed to drive forward.
- ➔ Place chocks under the trailer's wheel that will not be raised. Ensure that machine will not move during inspection.

- ➔ Raise the wheels (opposite to the side where chocks are placed).
 - ⇒ Lifting jack should be positioned in the place indicated by the arrow in figure (5.1). Lifting jack must be positioned in rotation point of rocker (1). Lifting jack must be suitable for the weight of the trailer.

Checking slackness of wheel axle bearings

- ➔ Turning the wheel slowly in both directions check that movement is smooth and that the wheel rotates without excessive resistance.
- ➔ Turn the wheel so that it rotates very quickly, check that the bearing does not make any unusual sounds.
- ➔ Holding the wheel above and below, try to feel any slackness.
 - ⇒ You may use a lever placed under the wheel supporting the other end on the floor.
- ➔ Lower the lifting jack, relocate the chocks to the other wheel and repeat the inspection procedure for the other wheels.

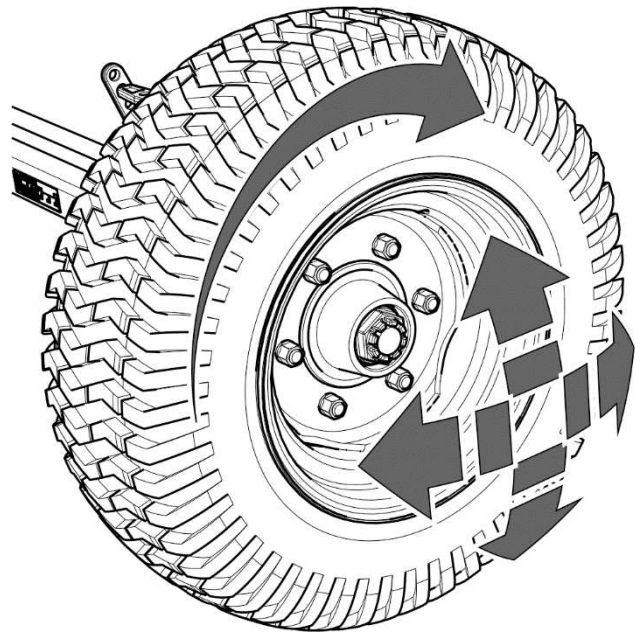

FIGURE 5.2 Checking bearings for slackness

TIP



If hub cover is damaged or missing, contamination and dampness enter the hub, which causes significantly faster wear of bearing and hub seals.

Bearing life is dependent on working conditions of trailer, loading, speed of travel and lubrication conditions.

If slackness is felt, adjust bearing. Unusual sounds coming from bearing may be symptoms of excess wear, dirt or damage. In such a case, the bearing and sealing ring should be replaced with new parts (if they are not suitable for further operation) or cleaned and greased again.

INSPECTION



Checking wheel axle bearings for slackness:

- *after travelling the first 1,000 km,*
- *after intensive use of trailer,*
- *every six months use or every 25,000 km.*

Check condition of hub cover, if necessary replace with a new cover. Inspection of bearing slackness may only be conducted when the trailer is hitched to tractor. The machine may not be loaded.

DANGER



Before commencing work the user must read the user's manual for the lifting jack and adhere to the manufacturer's instructions.

The lifting jack must be stably supported on the ground and the suspension system rocker.

Make certain that the lifting jack is positioned in the rocker's axis of rotation and that the trailer shall not move during inspection of half axle bearing slackness.

5.2.3 ADJUSTMENT OF SLACKNESS OF WHEEL AXLE BEARINGS

The wheel should turn smoothly without stiffness or detectable resistance. Adjustment of bearing slackness may only be conducted when the trailer is not loaded and is hitched to the tractor.

Ensure that the trailer is properly secured and will not move during wheel dismounting.

- ➔ Take off hub cover (1), figure (5.3).
- ➔ Take out cotter pin (3) securing castellated nut (2).

- ➔ Tighten castellated nut in order to eliminate slackness.
- ➔ Wheel should rotate with insignificant resistance.
- ➔ Undo nut (not less than 1/3 rotation) to align the nearest thread groove with the opening in wheel half axle pin. Wheel should rotate without excessive resistance.
- ➔ Nut may not be excessively tightened. Do not apply excessive pressure because working conditions of the bearings may deteriorate.
- ➔ Secure castellated nut with cotter pin and mount hub cap.
- ➔ Delicately tap hub cap with rubber or wooden hammer.

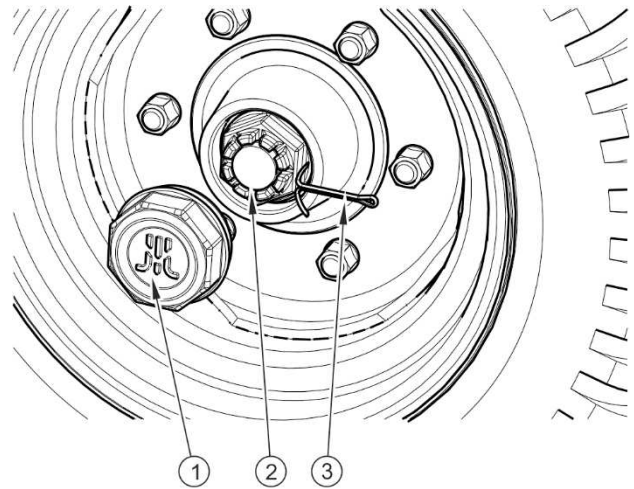

FIGURE 5.3 Adjustment of slackness
 (1) hub cover, (2) castellated nut, (3) cotter pin

5.2.4 MOUNTING AND DISMOUNTING WHEEL, INSPECTION OF WHEEL NUT TIGHTENING.

Dismounting wheel

- ➔ Place chocks under wheel that will not be dismantled.
 - ➔ Ensure that trailer shall not move during wheel dismantling.
 - ➔ Loosen wheel nuts according to the sequence shown in figure (5.4).
 - ➔ Place lifting jack and lift trailer.
- ⇒ The lifting jack should have sufficient lifting capacity and should be technically reliable.

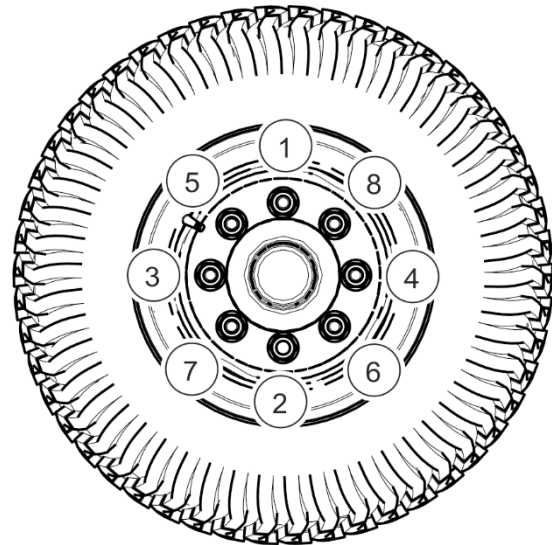

FIGURE 5.4 Sequence of undoing and tightening nuts

- ⇒ The lifting jack must be positioned on a level and hard surface so as to prevent sinking into the ground or relocating the jack during lifting.
 - ⇒ If necessary, use proper backing plates in order to prevent the lifting jack from sinking into the ground.
 - ⇒ Confirm that the lifting jack is positioned in rocker rotation point.
- ➔ Dismount wheel.

Wheel mounting

- ➔ Clean axle pins and nuts of contamination.
 - ⇒ Do not grease thread of nuts and pins.
- ➔ Check condition of pins and nuts, if necessary replace.
- ➔ Place wheel on hub, tighten nuts so that wheel rim tightly fits the hub.
- ➔ Lower trailer, tighten nuts according to recommended torque and given sequence.

Tightening nuts

Nuts should be tightened gradually diagonally, (in several stages, until obtaining the required tightening torque) using a torque spanner. Tightening of nuts should be checked with the frequency given in the below table. The activities should be repeated after each removal of a wheel from the wheel axle.

INSPECTION



Checking wheel tightening:

- *After the first use of trailer (one-time inspection).*
- *Every 2 – 3 hours of trailer travel (during the first month of trailer use).*
- *Every 30 hours of trailer travel.*
- *The above actions should be repeated individually if a wheel has been removed from the wheel axle.*

**TIP**

Wheel nuts should be tightened using the torque of 270 Nm - M18x1.5 nuts.

**ATTENTION**

Wheel nuts may not be tightened with impact wrench because of danger of exceeding permissible tightening torque, the consequence of which may be breaking the thread connection or breaking off the hub pins.

The greatest precision is achieved using a torque spanner. Before commencing work, ensure that correct tightening torque value is set.

5.2.5 CHECKING AIR PRESSURE IN TYRES, EVALUATING TECHNICAL CONDITION OF TYRES AND STEEL WHEELS

**TIP**

Tyre pressure values are specified in information decal, placed on wheel or on the frame above machine wheel.

Tyre pressure should be checked each time after changing spare wheel and not less than every month. In the event of intensive use, air pressure in tyres should be checked more frequently. During this time, the trailer must be unloaded. Checking should be done before travelling when tyres are not heated, or after an extended period of parking.

**DANGER**

Damaged tyres or wheels may be the cause of a serious accident.

While checking pressure pay attention to technical condition of wheels and tyres. Look carefully at tyre sides and check the condition of tread. In case of mechanical damage consult the nearest tyre service and check whether the tyre defect requires tyre replacement.

Wheels should be inspected with regard to distortion, breaking of material, breaking of welds, corrosion, especially in the area of welds and contact with tyre.



INSPECTION

- *Every month of use.*
- *Every week during intensive work.*

5.2.6 CHECKING THICKNESS OF BRAKE SHOE LININGS

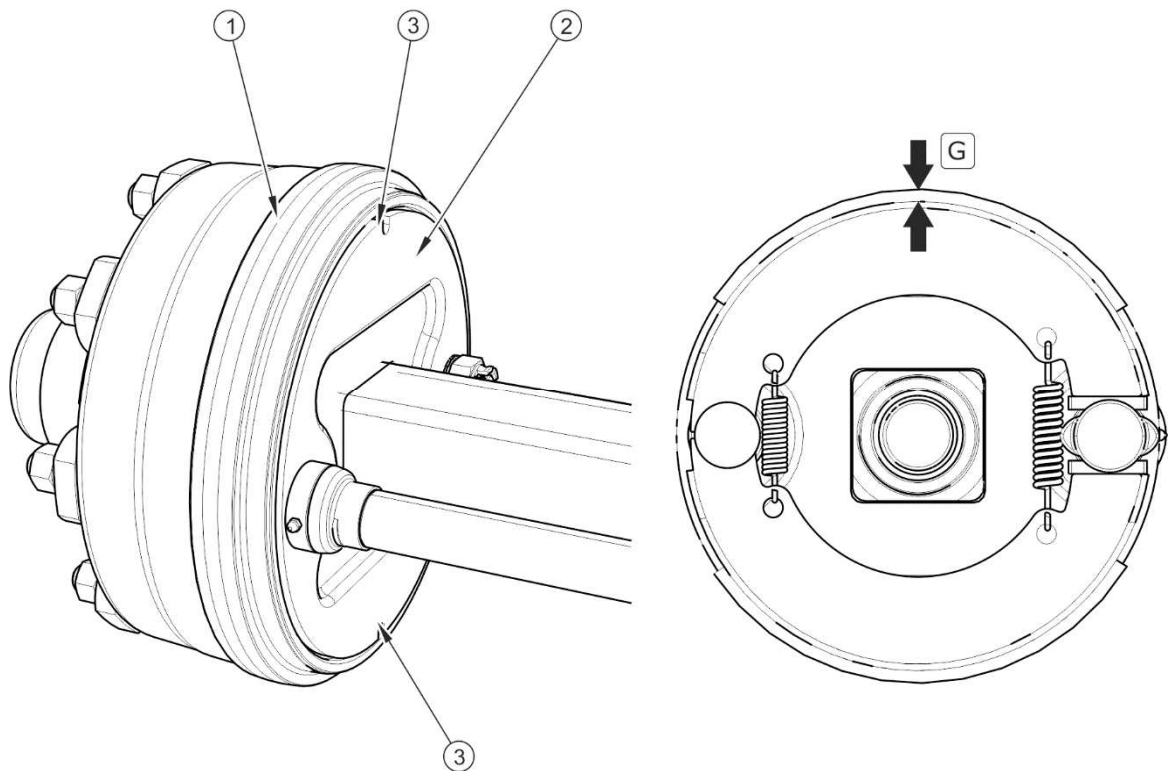

FIGURE 5.5 *Checking brake shoe linings*

(1) brake drum, (2) disc, (3) inspection openings, (G) thickness of brake shoe lining



TIP

Minimum thickness of brake shoe linings is 2 mm.

During use of trailer, friction lining of brake drums is subject to wear. In such a case, the complete brake shoes should be replaced with new ones. Excessive wear of brake shoes is the condition in which the thickness of linings which are glued or riveted to steel structures of brake shoes is smaller than the minimum value. This condition is indicated by extended cylinder rod stroke. Check technical condition of brake shoe linings through inspection openings (3) – figure (5.5).

5.2.7 MECHANICAL BRAKES ADJUSTMENT

Preliminary information

Considerable wear of brake shoe linings results in increased brake cylinder rod stroke and worse braking efficiency.

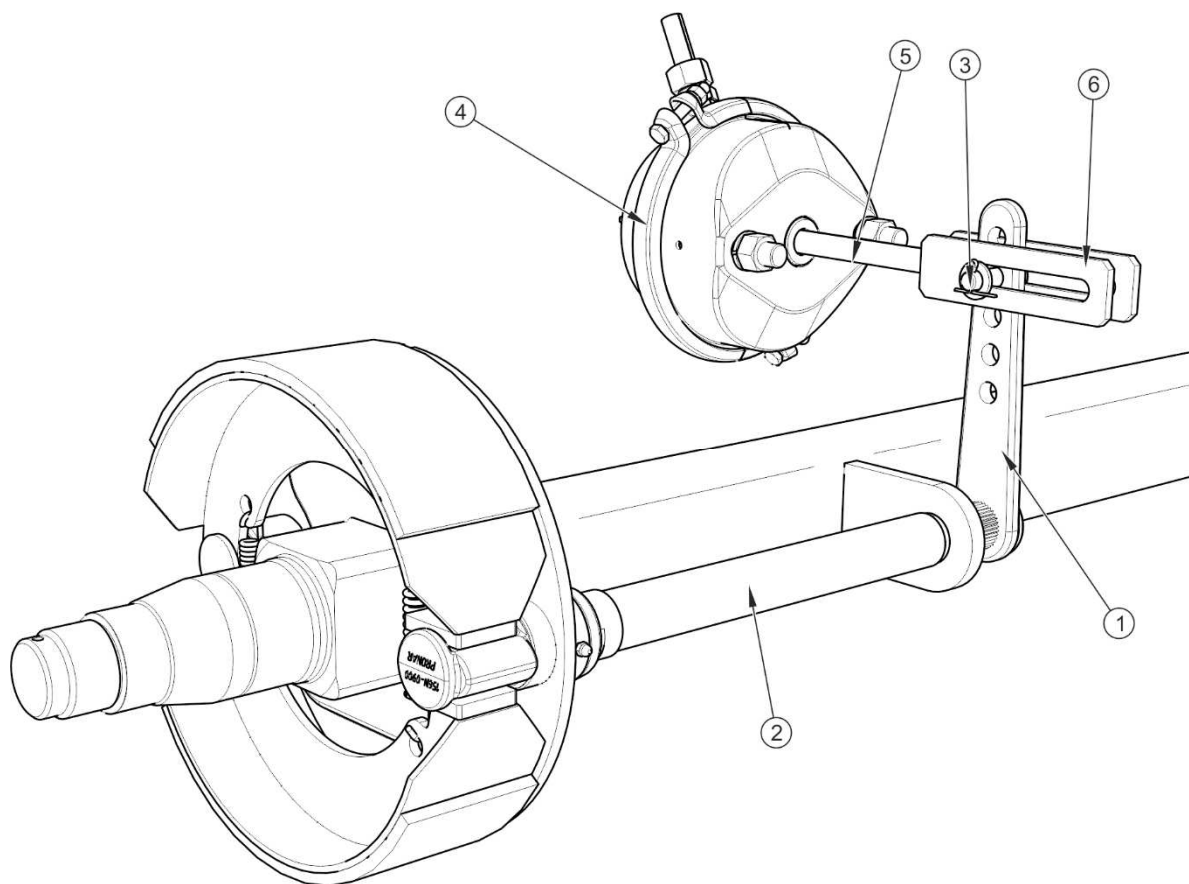

FIGURE 5.6 Design of pneumatic wheel axle brake

(1) expander arm, (2) expander shaft, (3) fork pin, (4) brake cylinder, (5) cylinder rod, (6) cylinder fork

**TIP**

Correct brake cylinder rod stroke should be within the range of 25 – 45 mm.

During braking, the brake cylinder rod stroke should be within the specified operating range and the angle between brake cylinder rod and expander arm should be about 90° – see figures (5.8) and (5.9).

**ATTENTION**

Incorrectly adjusted brake may cause rubbing of brake shoes against brake drums, which may lead to faster wear of brake linings and/or brake overheating.

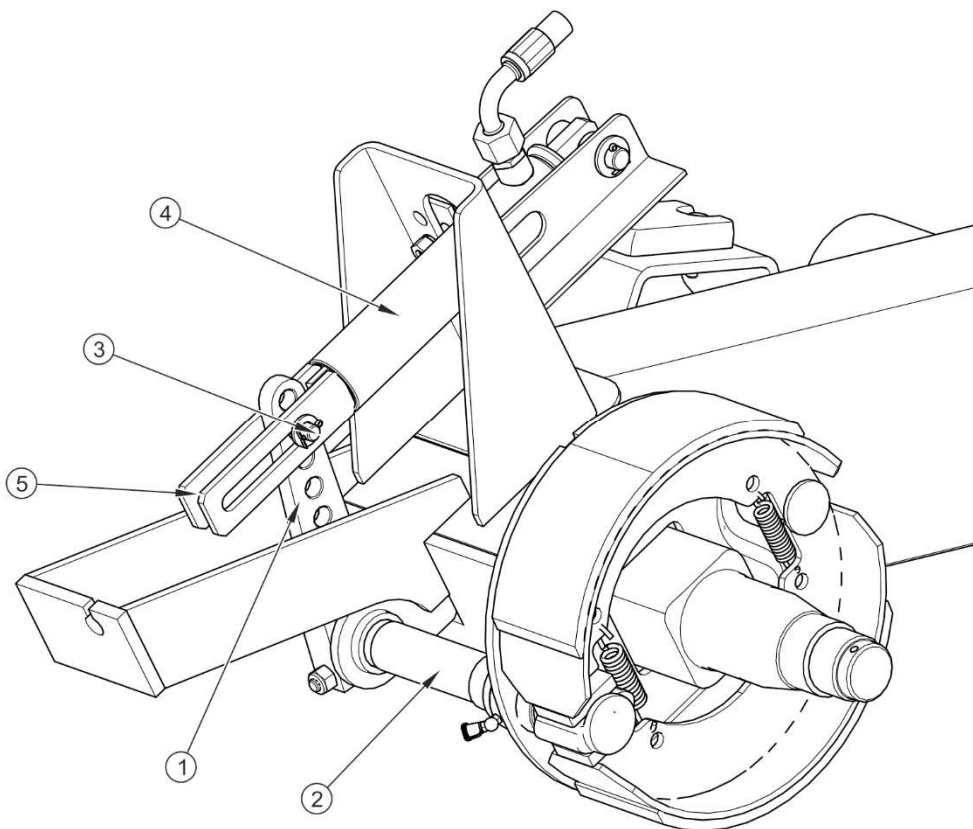

FIGURE 5.7 *Design of hydraulic wheel half axle brake*

(1) expander arm, (2) expander shaft, (3) fork pin, (4) brake cylinder, (5) cylinder rod, (6) cylinder fork

Braking force decreases also when the operating angle of the brake cylinder rod (4) – figure (5.8) in relation to the expander arm (1) is wrong. In order to obtain the optimum mechanical

operating angle, the cylinder rod fork (6) must be installed on the expander arm (1) in such a manner as to ensure that the operating angle at full braking is about 90°.

TABLE 5.1 *Operating data of pneumatic cylinder*

NOMINAL CYLINDER STROKE L [mm]	MINIMUM CYLINDER STROKE L _{MIN} [mm]	MAXIMUM CYLINDER STROKE L _{MAX} [mm]
75	25	45



INSPECTION

- *Check technical condition of brake every 6 months.*
- *After repair of braking system.*
- *In case of uneven trailer wheels braking.*

The inspection involves measuring the extension length of each brake cylinder rod while braking at parking. If the brake cylinder rod stroke exceeds the maximum value (45 mm), the braking system should be adjusted.

Required maintenance activities for pneumatic brakes

- ➔ Hitch trailer to tractor.
- ➔ Turn off tractor engine and remove key from ignition.
- ➔ Immobilise tractor with parking brake.
- ➔ Make sure that the trailer's brakes are not engaged.
- ➔ Secure the trailer with wheel chocks.
- ➔ Make a line (A) on the brake cylinder rod (1) to indicate the position of the maximum withdrawal of the brake cylinder rod – figure (5.8).
- ➔ Press the tractor brake pedal and mark the position of the maximum extension of the brake cylinder rod with a line (B).
- ➔ Measure the distance between lines (A) and (B). If the brake cylinder rod stroke is outside the proper operating range, adjust the expander arm.
- ➔ Dismantle brake cylinder fork pin.

- ➔ Remember or mark the original position (5) of brake cylinder fork (4) in expander arm opening (3).
- ➔ Check if the brake cylinder rod moves freely and within the whole nominal range.

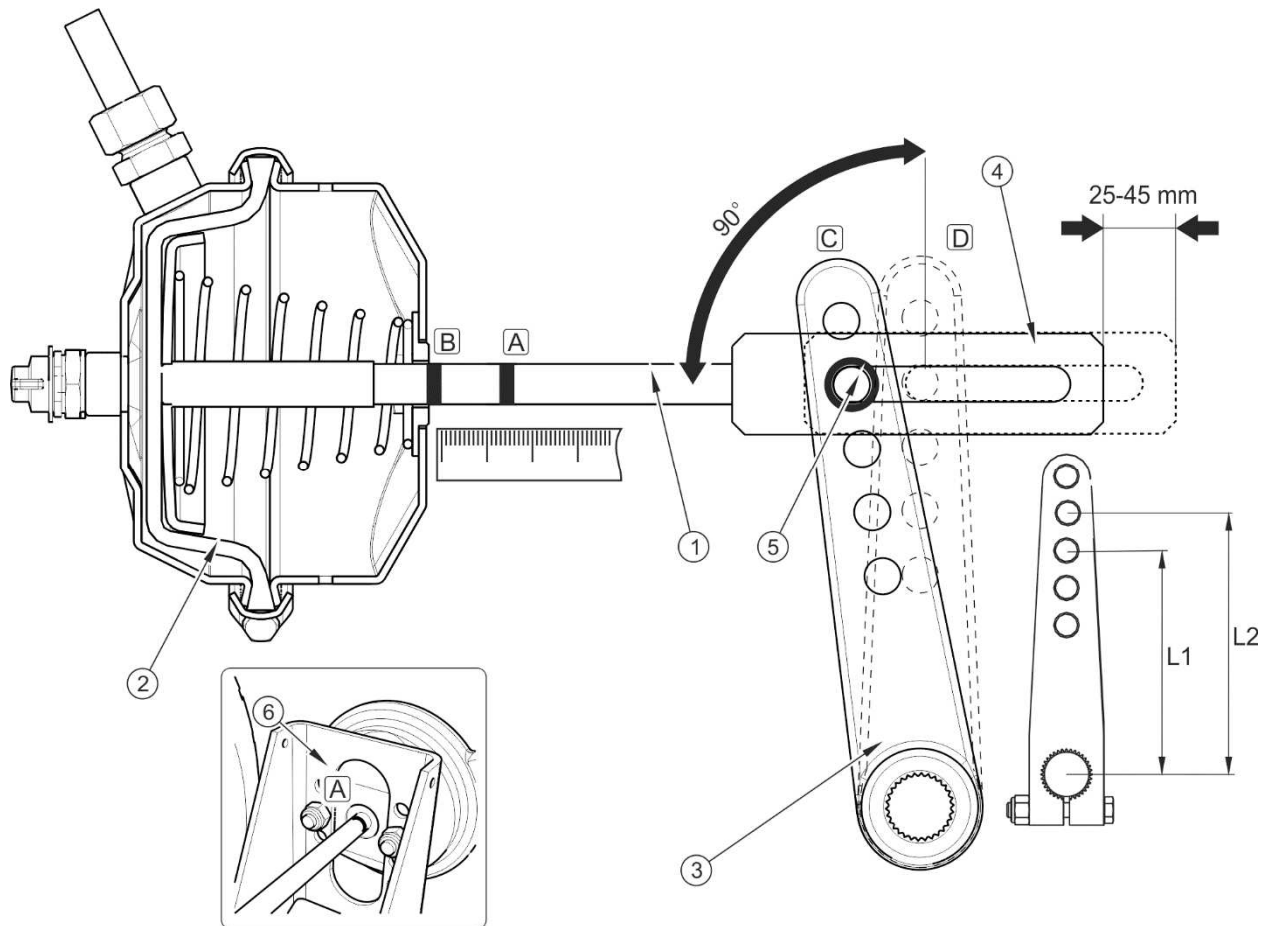

FIGURE 5.8 Principle of brake adjustment

(1) brake cylinder rod, (2) brake cylinder membrane, (3) expander arm, (4) cylinder fork, (5) position of fork pin, (6) brake cylinder bracket, (A) mark on the brake cylinder at brake release position, (B) mark on the brake cylinder at full braking position, (C) position of arm at brake release position, (D) position of arm at full braking position

- ➔ Check if the brake cylinder vent holes are not blocked with impurities and that there is no water or ice inside the brake cylinder. Check if the brake cylinder is correctly installed.
- ➔ Clean the brake cylinder. If necessary, defrost the brake cylinder and drain water through the unblocked vent holes. Replace damaged brake cylinder with

a new one. When installing the brake cylinder, maintain its original position with regard to bracket (6).

- ➔ Dismantle the expansion ring securing the expander arm.
- ➔ Shift the expander arm to align the marked expander arm opening with the cylinder fork opening.
 - ⇒ During adjustment, membrane (2) must rest on the rear wall of the brake cylinder – compare figure (5.8).
- ➔ Install the brake cylinder fork pin and washers and secure the pin with cotter pins.
- ➔ Repeat the adjustment activities for the second half axle.
- ➔ Engage the brake.
- ➔ Remove previous marks and measure the brake cylinder rod stroke again.
- ➔ If the brake cylinder rod stroke is outside the proper operating range, repeat the adjustment.

TABLE 5.2 *Position of pin in expander arm*

TRAILER MODEL	FRONT HALF AXLES	REAR HALF AXLES
T679/3 (L1)	175	175
T679/4 (L2)	150	150

The hydraulic braking system adjustment is performed in the same way by marking the extension of hydraulic cylinder rod (3) – figure (5.9).

TABLE 5.3 *Operating data of hydraulic cylinder*

NOMINAL CYLINDER STROKE L [mm]	MINIMUM CYLINDER STROKE L _{MIN} [mm]	MAXIMUM CYLINDER STROKE L _{MAX} [mm]
200	25	45

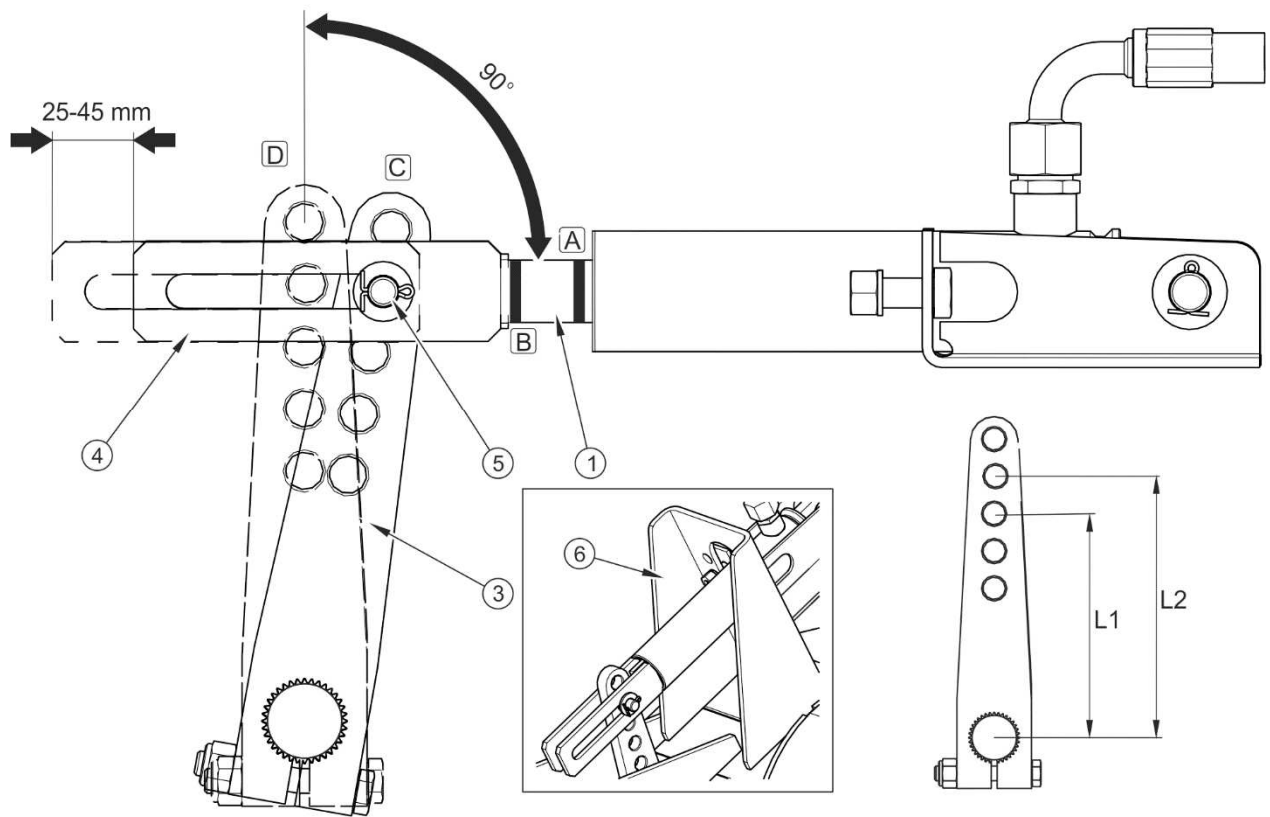

FIGURE 5.9 Principle of brake adjustment

(1) brake cylinder rod, (3) expander arm, (4) cylinder fork, (5) position of fork pin, (6) brake cylinder bracket, (A) mark on the brake cylinder at brake release position, (B) mark on the brake cylinder at full braking position, (C) position of arm at brake release position, (D) position of arm at full braking position

ATTENTION



The positions for fixing the brake cylinder in the bracket openings and the brake cylinder pin in the expander arm are determined by the Manufacturer and must not be changed.

Each time when dismantling the pin or brake cylinder, the original fixing position should be marked.

5.2.8 CHANGE OF PARKING BRAKE CABLE AND ADJUSTMENT OF CABLE TENSION.

Proper operation of the parking brake is dependent on the effectiveness of the half axle brake and the correct brake cable tension.

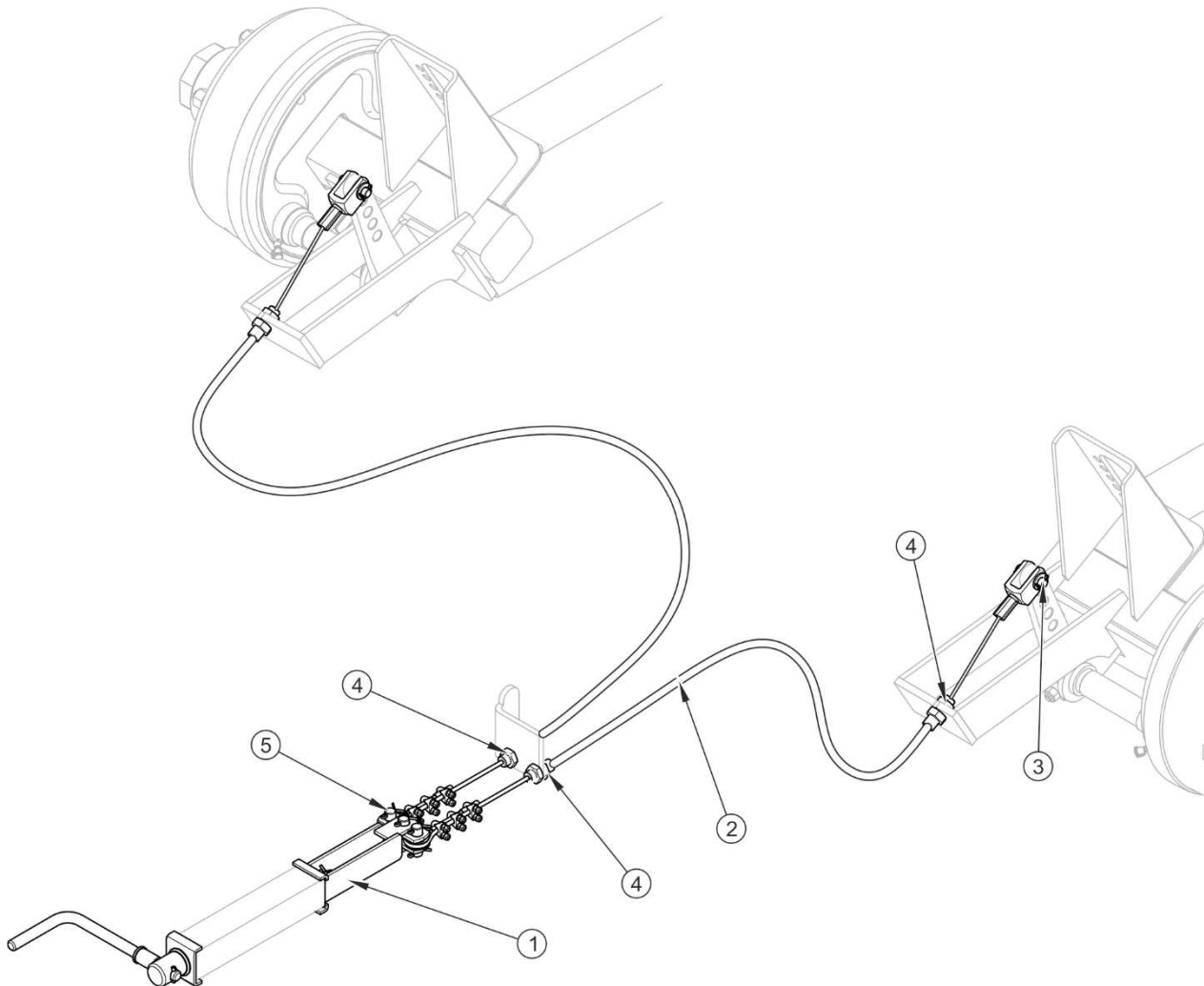

FIGURE 5.10 *Disassembly of the parking brake cable*

(1) brake mechanism, (2) cable, (3) fork pin, (4) nut, (5) mechanism pin

Replacing the parking brake cable

- ➔ Hitch trailer to tractor. Park machine and tractor on level surface.
- ➔ Prevent the trailer from rolling by placing chocks under the wheels. Immobilise tractor with parking brake.
- ➔ Fully unscrew the bolt of the handbrake mechanism.

- ➔ Dismount the fork pin protection. Remove fork pin (3).
- ➔ Undo cable securing nuts (4).
- ➔ Dismount the mechanism pin protections. Remove pin (5).
- ➔ Pull out cable (2).
- ➔ Install the cable in reverse order.

Adjustment of parking brake cable tension

- ➔ Hitch trailer to tractor. Park machine and tractor on level surface.
- ➔ Prevent the trailer from rolling by placing chocks under the wheels. Immobilise tractor with parking brake.
- ➔ Fully unscrew the bolt of the handbrake mechanism.
- ➔ Loosen all nuts (2) – figure (5.11), of handbrake cable clamps on the brake mechanism side.
- ➔ Tighten cable and tighten clamps.

ATTENTION



Parking brake cable clamps must be installed as shown in figure (5.11), i.e. clamp bracket (2) must be installed on the side of the shorter brake cable section. Tighten nuts using tightening torque given in table TIGHTENING TORQUE FOR NUT AND BOLT CONNECTIONS



INSPECTION

- *Every 12 months.*

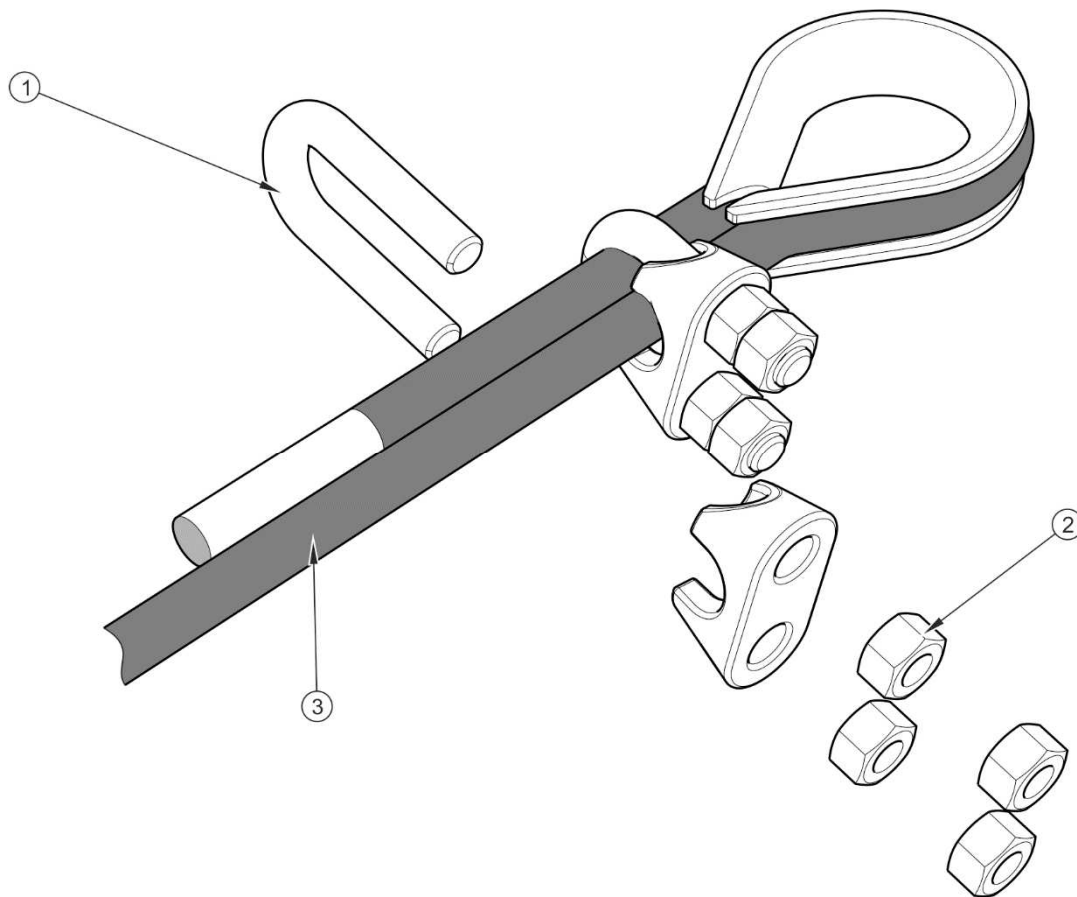

FIGURE 5.11 *Installing the parking brake cable*

(1) U-bolt clamp, (2) nuts of clamps, (3) handbrake cable

Length of parking brake cable should be so selected that at total release of working and parking brake the cable would be loose.

Adjustment of parking brake cable tension should be conducted in the event of:

- stretching of cable,
- loosening of parking brake cable clamps
- after adjustment of axle brakes,
- after repairs of axle brake system,
- after repairs of parking brake system.

Before commencing adjustment make certain that the main break is correctly regulated and is functioning properly.

5.3 PNEUMATIC SYSTEM MAINTENANCE

5.3.1 PRELIMINARY INFORMATION

Work connected with repair, replacement or regeneration of system components (brake cylinders, conduits, control valve, braking force regulator, etc.) should be entrusted to specialist establishments, having the appropriate technology and qualifications for this type of work.

The duties of the operator connected with the pneumatic system include:

- checking tightness and visual inspection of the system,
- cleaning the air filters,
- draining water from air tank,
- cleaning drain valve,
- cleaning and maintaining pneumatic conduit connections,



DANGER

Do NOT use the trailer when brake system is unreliable.

5.3.2 CHECKING TIGHTNESS

Checking air tightness of pneumatic system

- ➔ Hitch trailer to tractor. Park machine and tractor on level surface.
- ➔ Prevent the trailer from rolling by placing chocks under the wheels. Immobilise tractor and trailer with parking brake.
- ➔ Start the tractor in order to supplement air in the trailer braking system tank.
 - ⇒ In double conduit systems air pressure should amount to approx. 6.5 bar.
 - ⇒ In single conduit systems air pressure should amount to approx. 5.8 bar.

- Turn off tractor engine.
- Check system components by releasing brake pedal in tractor.
 - ⇒ Give particular attention to conduit connections and brake cylinders.
- Repeat the system check with depressed tractor brake pedal.
 - ⇒ The help of a second person is required.

In the event of the appearance of leaks, compressed air will escape at the places of damage, with a characteristic hiss. Lack of system tightness may be also detected by covering checked elements with washing fluid or other foaming preparations, which will not react aggressively with system components. It is recommended to supply preparations commercially available designed to facilitate detecting air leaks. Damaged components should be replaced or repaired. If leaks appear at connections then tighten the connections. If air continues to escape, replace connection components or seals.

INSPECTION



- *After travelling the first 1,000 km.*
- *Each time after making repairs or changing system components,*
- *Every 12 months.*

5.3.3 INSPECTION OF THE SYSTEM

INSPECTION



- *Each time during tightness inspection.*

During tightness inspection attention should additionally be given to technical condition and degree of cleanness of the system components. Contact of pneumatic conduit seals etc. with oil, grease, petrol etc. may cause damage and accelerate the ageing process. Bent, permanently deformed, cut or worn conduits should be replaced.

5.4 CLEANING THE AIR FILTERS

Depending on trailer working conditions, but not less than once in three months, take out and clean air filter inserts, which are located in pneumatic system connection conduits. Inserts are used many times and are not subject to changing unless they are mechanically damaged.

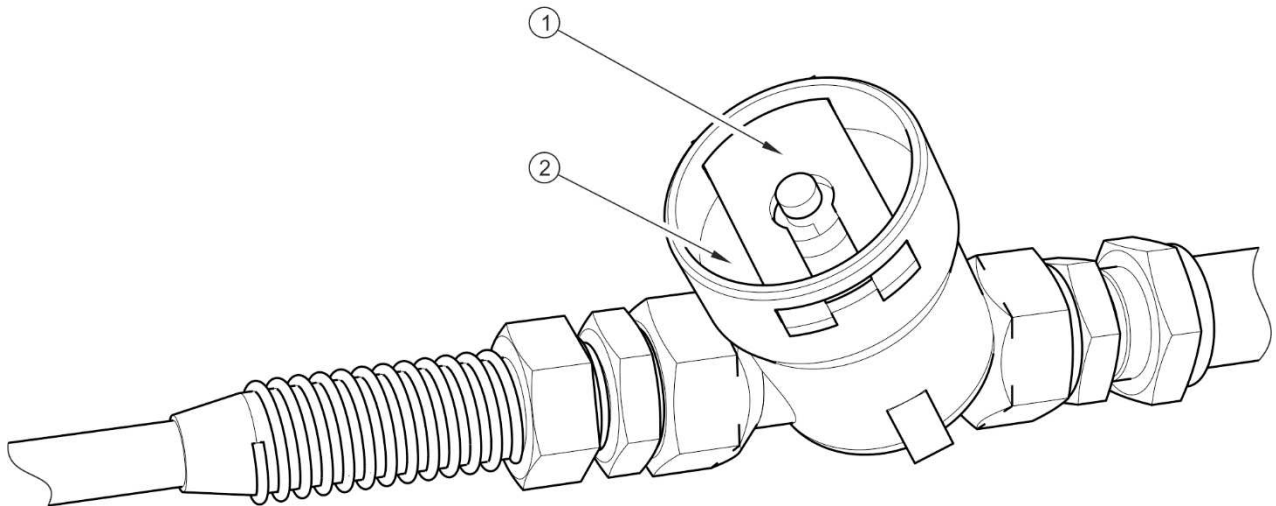

FIGURE 5.12 Air filter

(1) securing slide lock, (2) air filter cover



DANGER

Before proceeding to dismantle filter, reduce pressure in supply conduit. While disengaging filter slide gate, hold cover with other hand. Stand away from filter cover vertical direction.

Required maintenance activities

- ➔ Reduce pressure in supply conduit.
 - ⇒ Pressure in conduit can be reduced by pressing the head of the pneumatic connection until resistance is felt.
- ➔ Remove securing slide (1).
- ➔ Hold the filter cover (2) with the other hand. After removing slide lock, the cover is pushed off by the spring located in the filter housing.



INSPECTION

- *Every 3 months.*

- ➔ The filter insert and the filter body should be carefully washed out and blown through with compressed air. Assembly should be done in reverse order.

5.4.1 DRAINING WATER FROM AIR TANK

Required maintenance activities

- ➔ Tilt drain valve stem (2) located in the lower part of tank (1).
- ➔ The compressed air in the tank causes the removal of water to the exterior.
- ➔ Released valve stem should automatically close and stop flow of air from the tank.
- ➔ In the event, that the valve stem resists returning to its setting, then the whole drain valve must be unscrewed and cleaned, or replaced (if it is damaged) - see section *CLEANING DRAIN VALVE*.

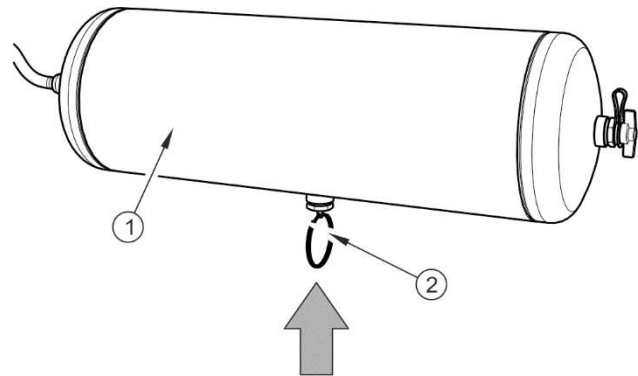

FIGURE 5.13 *Draining water from the tank*

(1) air tank, (2) drain valve

5.4.2 CLEANING DRAIN VALVE

Required maintenance activities

- ➔ Completely reduce pressure in air tank.
 - ⇒ Reduction of pressure in tank is achieved by tilting the drain valve stem.
- ➔ Unscrew both valves.
- ➔ Clean the valve and blow it with compressed air.

- ➔ Change copper seals.
- ➔ Screw valves in, fill tanks with air, check tightness.

**DANGER**

Release air from the air tank before dismantling drain valve.

**INSPECTION**

- *Every 12 months (before winter).*

5.4.3 CLEANING AND MAINTAINING PNEUMATIC CONDUIT CONNECTIONS AND PNEUMATIC SOCKETS

**DANGER**

Unreliable and dirty trailer connections may cause unreliability and faulty functioning of braking system.

Connection with damaged body should be replaced. In the event of damage to cover or seal, change these elements for new reliable elements. Contact of pneumatic connection seals with oils, grease, petrol etc. may cause damage and accelerate ageing process.

**INSPECTION**

- *Each time before hitching trailer to tractor.*

If the trailer is unhitched from the tractor, connections should be protected by cover or placed in their designated socket. Before the winter period it is recommended to preserve the seal with special preparations (e.g. silicon grease for rubber elements).

Each time before hitching the machine, inspect technical condition and cleanness of connectors and sockets in tractor. If necessary, clean or repair tractor sockets.

5.5 HYDRAULIC SYSTEM MAINTENANCE

5.5.1 PRELIMINARY INFORMATION

Work connected with the repair, replacement or regeneration of hydraulic system components should be entrusted to specialist establishments which have the appropriate technology and qualifications for this type of work.



TIP

Bleeding of the hydraulic system is not required during normal operation of the trailer.

The duties of the operator connected with the maintenance of hydraulic systems include:

- checking tightness and visual inspection of the system,
- checking technical condition of hydraulic connections.

5.5.2 CHECKING HYDRAULIC SYSTEM TIGHTNESS

Required maintenance activities

- ➔ Hitch trailer to tractor.
- ➔ Connect the tipping system conduit according to the recommendations in the Operator's Manual.
- ➔ Clean connections and hydraulic cylinders (tipping cylinder, tailgate cylinder and hydraulic brake system cylinders).
- ➔ Start the tractor's engine and raise and lower the load box several times. Check operation of cut-off valve. Leave the cylinder in the maximally extended position.
- ➔ Connect the tailgate system conduits.
- ➔ Open and close the tailgate several times.
- ➔ Connect the hydraulic braking system conduit.
- ➔ Depress the tractor brake pedal.

- ➔ Switch off the tractor's engine and check all hydraulic cylinders for tightness.

If oil is found on hydraulic cylinder body, check origin of leak. Inspect seals when hydraulic cylinder is completely extended. Minimum leaks are permissible with symptoms of "sweating". However, if leaks in the form of "droplets" are noticed, stop using the trailer. If leaks appear at connections then tighten the connections. If the leak at connections is not removed, replace conduit, connector and seals (depending on place of leakage).



INSPECTION

- *After the first week of use.*
- *Every 12 months.*

5.5.3 CHECKING TECHNICAL CONDITION OF HYDRAULIC CONNECTIONS AND SOCKETS.

Hydraulic connections must be technically reliable and kept in a clean condition. Each time before connecting, check if sockets in tractor are maintained in good working condition. Hydraulic systems of the tractor and trailer are sensitive to the presence of permanent contamination, which may cause damage to precision system components.



INSPECTION

- *Each time before connecting trailer to tractor or before connecting the second trailer.*

5.5.4 REPLACEMENT OF HYDRAULIC CONDUITS



INSPECTION

- *Every 4 years.*

Rubber hydraulic conduits must be replaced every 4 years regardless of their technical condition. This should be entrusted to specialised workshops.

5.6 LUBRICATION

Trailer lubrication should be performed with the aid of a manually or foot operated grease gun, filled recommended grease. Before commencing work insofar as is possible remove old grease and other contamination. Remove and wipe off excess oil or grease.

Change of grease in hub bearings should be entrusted to specialised service points, equipped with the appropriate tools. According to the recommendations of the axle Manufacturer, dismantle the entire hub, remove the bearing and individual sealing rings. After careful washing and inspection, mount lubricated elements. If necessary, bearing and seals should be replaced with new parts. Lubrication of axle bearings shall be performed at least once in 2 years.

TABLE 5.4 *Lubrication schedule*

ITEM	LUBRICATION POINT	NUMBER OF LUBRICATION POINTS	TYPE OF GREASE	FREQUENCY
1	Hub bearing	8	A	24M
2	Drawbar eye	1	B	14D
3	Brake expander arm	4	A	3M
4	Sockets of tipping cylinder and cylinder suspension	4	B	1M
5	Tipping cylinder ball bearing	1	B	3M
6	Parking brake mechanism	1	A	6M
7	Mechanical support mechanism	1	A	6M
8	Tipping pins	2	B	3M
9	Tailgate cylinder bearing	1	A	3M
10	Tailgate securing pin	7	A	3M

ITEM	LUBRICATION POINT	NUMBER OF LUBRICATION POINTS	TYPE OF GREASE	FREQUENCY
11	Automatic rear hitch ⁽¹⁾	1	A	6M
12	Tailgate slide rollers	1	A	3M
13	Rocker arm pin	6	B	1M
14	Swing hinge of hinged-opening tailgate ⁽¹⁾	2	A	3M

Lubrication periods – M months, D – days

⁽¹⁾ – non-standard equipment

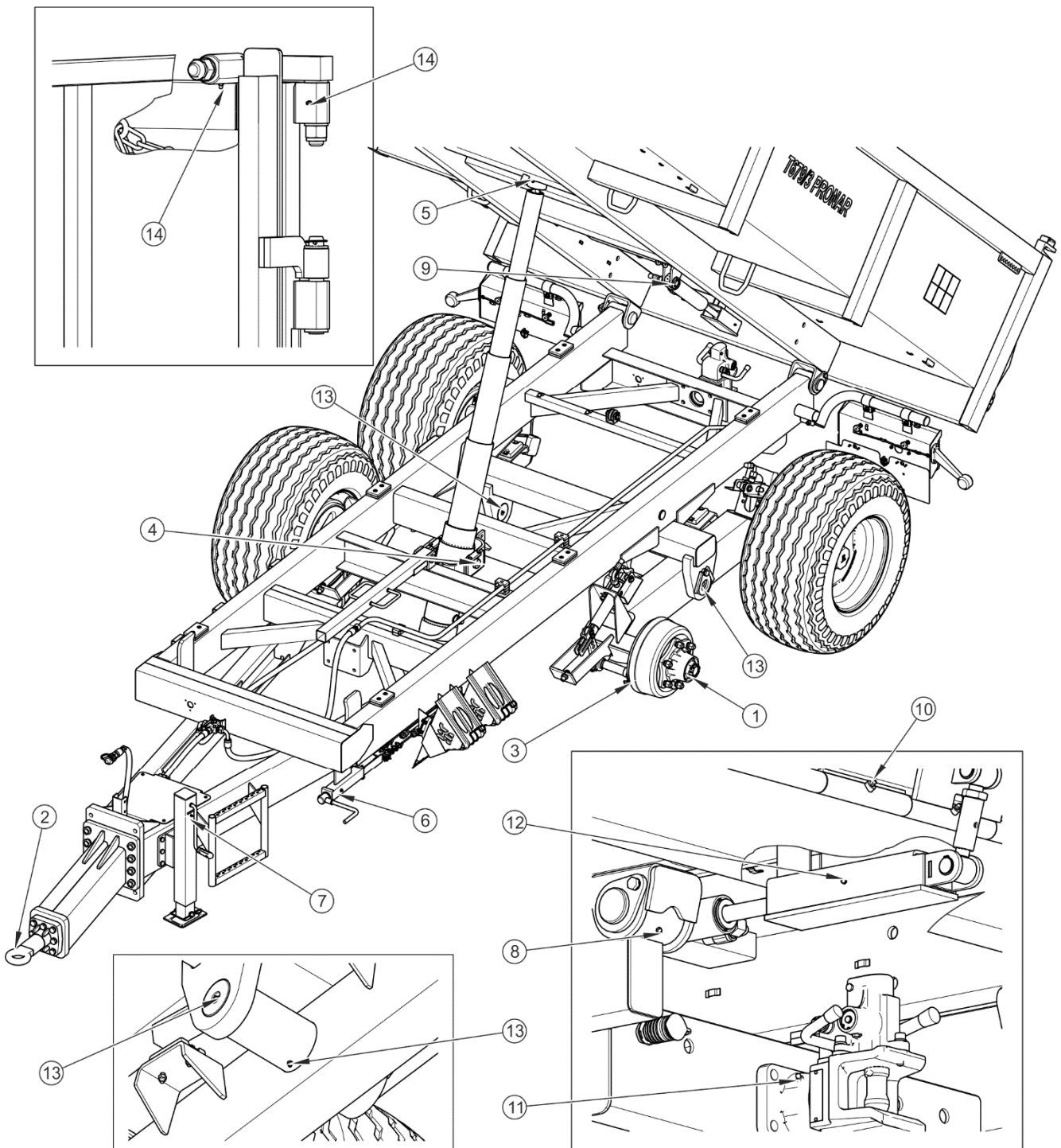

FIGURE 5.14 Trailer's lubrication points

TABLE 5.5 *Recommended lubricants*

MARKING ACCORDING TO TAB. (5.3)	DESCRIPTION
A	Machine general-purpose grease (lithium, lime).
B	Grease for heavily loaded elements with addition of MoS ₂ or graphite.
C	Anti-corrosion and penetrating preparation in aerosol.

Empty grease or oil containers should be disposed of according to the recommendations of the lubricant Manufacturer.

TIP

Number of lubrication points and subassemblies requiring lubrication specified in table (5.4) LUBRICATION SCHEDULE depend on the trailer version.

Locations of grease nipples and areas requiring lubrication are indicated by black arrows in figure (5.14).

5.6.1 CONSUMABLES**Hydraulic oil**

Always adhere to the principle that the oil in the trailer hydraulic system and in the tractor hydraulic system are of the same type. In the event of application of different types of oil make certain that both hydraulic substances may be mixed together. Application of different oil types may cause damage to trailer or tractor. In a new machine, the hydraulic system is filled with L HL32 Lotos hydraulic oil.

In the event of necessity of changing hydraulic oil for another oil, check the recommendations of the oil Manufacturer very carefully. If it is recommended to flush the system with the appropriate preparation, then comply with these recommendations. Attention should be given, so that chemical substances used for this purpose do not damage the materials of the hydraulic system. During normal trailer use, change of hydraulic oil is not necessary, but if required, this operation should be entrusted to a specialist service point.

TABLE 5.6 *L-HL 32 Lotos hydraulic oil characteristics*

ITEM	NAME	UNIT	VALUE
1	ISO 3448VG viscosity classification	-	32
2	Kinematic viscosity at 40°C	mm ² /s	28.8 – 35.2
3	ISO 6743/99 quality classification	-	HL
4	DIN 51502 quality classification	-	HL
5	Flash-point	C	230

Because of its composition the oil applied is not classified as a dangerous substance, however long-term action on the skin or eyes may cause irritation. In the event of contact of oil with skin wash the place of contact with water and soap. Do NOT apply organic solvents (petrol, kerosene). Contaminated clothing should be changed to prevent access of oil to skin. In the event of contact of oil with eye, rinse with large quantity of water and in the event of the occurrence of irritation consult a doctor. Hydraulic oil in normal conditions is not harmful to the respiratory tract. A hazard only occurs when oil is strongly atomised (oil vapour), or in the case of fire during which toxic compounds may be released.

**DANGER**

Oil fires should be quenched with the use of carbon dioxide, foam or extinguisher steam. Do not use water to quench oil fires.

Lubricants

For heavily loaded parts it is recommended to apply lithium greases with addition of molybdenum disulphide (MOS₂) or graphite. In the case of less loaded sub-assemblies the application of general purpose machine greases is recommended, which contain anticorrosion additives and have significant resistance to being washed away by water. Similar characteristics should typify aerosol preparations (Silicon greases and anticorrosive lubricant substances).

Before starting to use greases acquaint oneself with the content of the information leaflet for the chosen product. Particularly relevant are safety rules and handling procedures for given

lubricant product and waste utilisation (used containers, contaminated rags etc.). Information leaflet (material safety data sheet) should be kept together with grease.

5.7 TRAILER CLEANING

- The trailer should be cleaned as needed. Before using pressure washer the user is obliged to acquaint himself with the operating principles and recommendations concerning safe use of this equipment.
- The trailer only be cleaned with clean running water. Cleaning detergents with neutral pH may be used, which do not react aggressively with the trailer's structural elements.
- Using pressure washer increases washing effectiveness, but particular care must be taken during work. During washing, washer nozzle may not be closer than 50 cm from the surface being cleaned.
- Water temperature shall not exceed 55°C.
- Do not direct water jets at system elements and equipment of the trailer i.e. control valve, braking force regulator, brake cylinders, hydraulic cylinders, pneumatic, electric and hydraulic plugs, lights, electrical connections, information and warning decals, identification plate, conduit connections, lubrication points of the trailer, etc. High pressure water jets may get inside the machine and cause mechanical damage or corrosion.
- For cleaning and maintenance of plastic coated surfaces it is recommended to use clean water or special preparations designed for this purpose.
- Do not apply organic solvents, preparations of unknown origin or other substances, which may cause damage to lacquered, rubber or plastic surfaces. In the event of doubt it is recommended to make a test on an unseen surface area.
- Surfaces smeared with oil or grease should be cleaned by application of benzene or other degreasing agents and then washed with clean water with added detergent. Comply with recommendations of the Manufacturer of cleaning agents.

- Washing detergent should be kept in original containers, optionally in replacement containers, but very clearly marked. Preparations may not be stored in food and drink containers.
- Ensure cleanliness of elastic conduits and seals. The plastic from which these elements are made may be susceptible to organic substances and some detergents. As a result of long-term reaction of some substances, the ageing process may be accelerated and risk of damage increased. Rubber elements should be maintained with the aid of special preparations after previous thorough washing.

DANGER



Carefully read the instructions for application of detergents and maintenance preparations.

While washing with detergents wear appropriate protective clothing and goggles protecting against splashing.

- Observe environmental protection principles and wash trailer in a place designed for this purpose.
- Washing and drying the trailer must take place at temperatures above 0°C.

5.8 STORAGE

- Trailer should be kept in a closed or roofed building.
- If the machine will not be used for a long time, it is essential to protect it from adverse weather, especially rust and accelerated tyre deterioration. During this time the machine must be unloaded. Trailer should be very carefully washed and dried.
- Corroded places should be cleaned of rust, degreased and protected using undercoat paint and then painted with surface paint according to colour scheme.
- In the event of prolonged work stoppage, it is essential to lubricate all elements regardless of the period of the last lubrication process.

- Wheel rims and tyres should be carefully washed and dried. During a longer storage of unused trailer it is recommended that the machine should be moved a bit once every 2 - 3 weeks in order to change the place of contact of tyres with the ground. The tyres will not be deformed and maintain proper geometry. Also, tyre pressure should be inspected from time to time, and if necessary pressure should be increased to the appropriate value.

5.9 INSPECTION OF TIGHTENING TORQUE OF NUT AND BOLT CONNECTIONS

5.9.1 TIGHTENING TORQUE FOR NUT AND BOLT CONNECTIONS



TIP

Hydraulic conduits should be tightened using torque of 50 – 70 Nm.

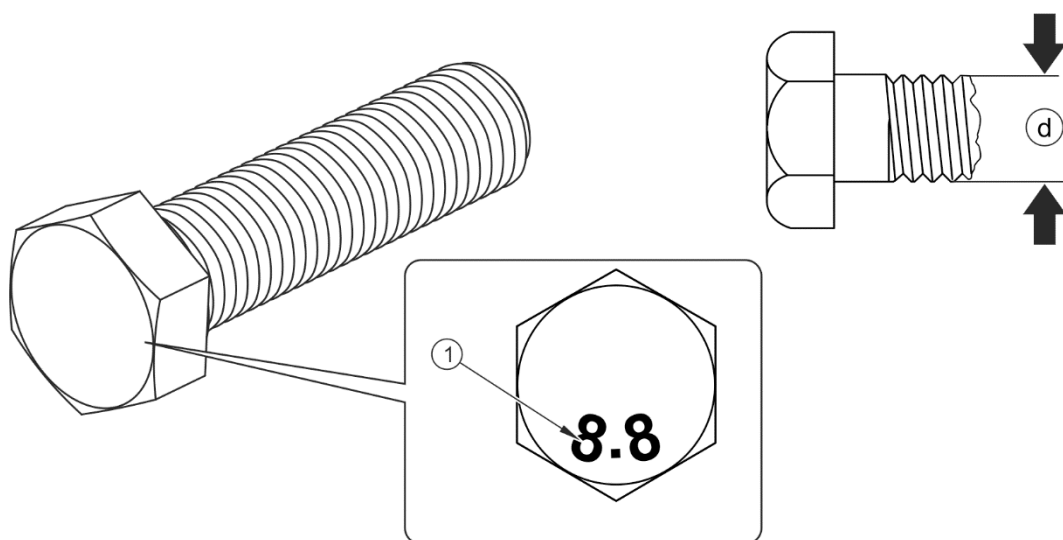

FIGURE 5.15 Bolt with metric thread

(1) strength class, (d) thread diameter

Unless other tightening parameters are given, during maintenance repair work apply appropriate torque to tighten nut and bolt connections. Recommended tightening torque

values for the most frequently used bolt and nut connections are given in table (5.7). Given values apply to non-lubricated steel bolts.

TABLE 5.7 *Tightening torque for nut and bolt connections*

THREAD METRIC	5.8 ⁽¹⁾	8.8 ⁽¹⁾	10.9 ⁽¹⁾
	Md [Nm]		
M10	37	49	72
M12	64	85	125
M14	100	135	200
M16	160	210	310
M20	300	425	610
M24	530	730	1,050
M27	820	1,150	1,650
M30	1,050	1,450	2,100

(1) – resistance class according to DIN ISO 898 standard

	<p>INSPECTION</p> <ul style="list-style-type: none"> • <i>Once, after purchasing the trailer, before first use.</i> • <i>Every 12 months.</i> • <i>Every 3 months during intensive work.</i>
---	--

5.10 ADJUSTMENT OF DRAWBAR POSITION

Location of the drawbar should be selected individually depending on the height of the hitch on the tractor that will pull the trailer. If possible, we recommend adjusting the tractor hitch so that the trailer drawbar is positioned horizontally while driving on a flat terrain.

The transition from lower to the upper hitch and vice versa is achieved by reversing the drawbar (1) by 180 degrees and mounting it to the faceplate (2).

The drawbar height is controlled through the appropriate use of the holes on the drawbar plate (1) relative to the faceplate (2) - figure (5.16). Drawbar positions (3) or (4) can also be adjusted by changing their position relative to the drawbar faceplate (1).

Scope of adjustment activities

- ➔ Immobilise trailer with parking brake.
- ➔ Place chocks under trailer wheels.
- ➔ Dismantle drawbar (1) from faceplate (2) by removing fixing bolts (5).

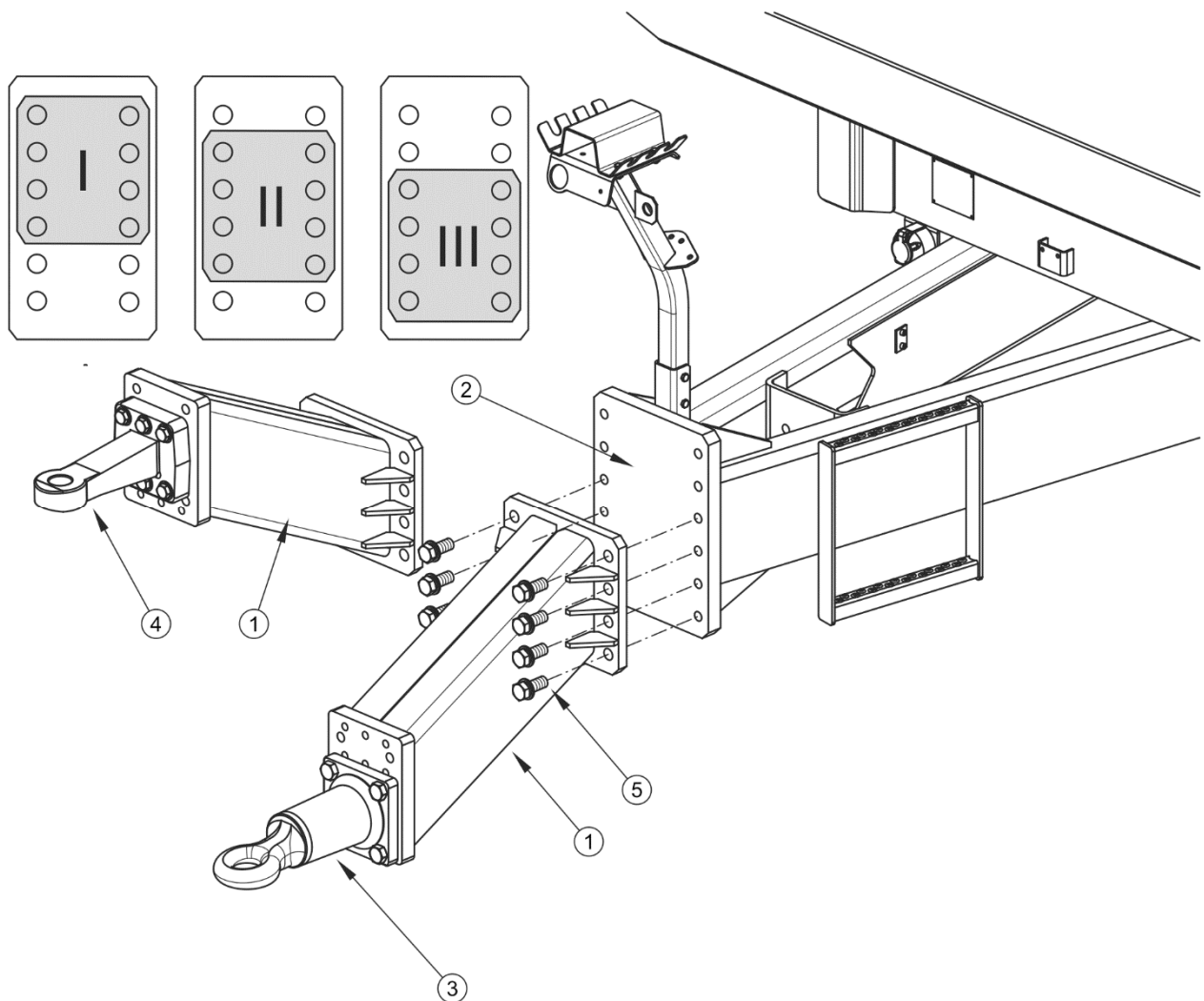

FIGURE 5.16 Adjustment of drawbar position

(1) drawbar, (2) faceplate, (3) rotating drawbar eye, (4) fixed drawbar eye, (5) fixing bolt

- ➔ If necessary, rotate the drawbar (1) by 180 degrees and set it in a new position.

- ⇒ Tighten the bolts (5) using the correct torque according to table (5.7).
- ⇒ The design of the drawbar (1), and the faceplate (2) allows the three settings (I) (II) (III).
- Set and mount the rotating drawbar eye (3), or fixed drawbar eye (4) in the appropriate position.
 - ⇒ The design of drawbar (1) allows two settings of the drawbar hitching eye.

5.11 ADJUSTMENT OF TAILGATE POSITION

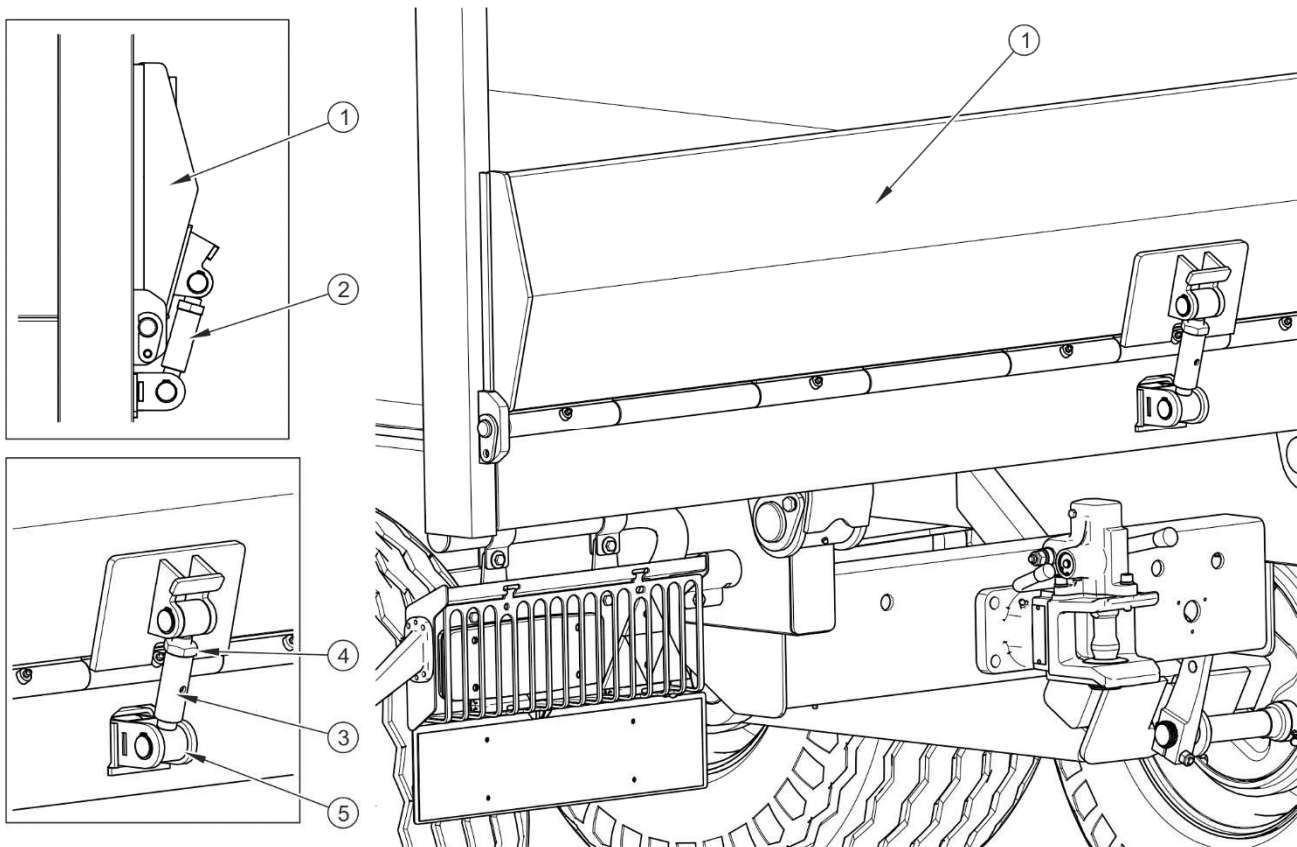

FIGURE 5.17 Adjustment of tailgate position

(1) hydraulic tailgate, (2) pressure adjustment, (3) adjustment nut, (4) nut, (5) slide

The tailgate position should be checked during trailer operation. If the tailgate position is incorrect, a gap will occur between the side edge of the tailgate and the rear surface of the load box. If both surfaces do not adhere precisely to each other, the load box is not tight and

scattering of bulk materials may occur. When adjusting the tailgate, reduce the gap to minimum.

Scope of adjustment activities

- ➔ Hitch trailer to tractor. Park machine and tractor on level surface.
- ➔ Connect conduits of the tailgate hydraulic system.
- ➔ Prevent the trailer from rolling by placing chocks under the wheels. Immobilise tractor and trailer with parking brake.
- ➔ Start the tractor's engine, open and close the tailgate. Check if closed tailgate adheres to the trailer's load box.
- ➔ If the gap is detected during visual inspection, adjust the position of closed tailgate(1).
- ➔ Loosen securing nut (4).
- ➔ Using adjustment bolt (3), set the tailgate position to reduce the gap between the surfaces of the load box and tailgate to minimum.
- ➔ Tighten nut (3).
- ➔ Start the tractor's engine; check operation of the tailgate and size of the gap between the closed tailgate and the load box.

5.12 TROUBLESHOOTING

5.12.1 TROUBLESHOOTING

FAULT	CAUSE	REMEDY
Problem with moving off	Brake system conduits not connected	Connect brake conduits (applies to pneumatic systems)
	Applied parking brake	Release parking brake.
	Damaged pneumatic system connection conduits	Replace.
	Leaking connections	Tighten, replace washers or seal sets, replace conduits.

FAULT	CAUSE	REMEDY
	Control valve or braking force regulator damaged	Check valve, repair or replace.
Noise in axle hubs	Excessive bearing slackness	Check slackness and adjust if needed
	Damaged bearing	Replace bearing
	Damaged hub parts	Replace
Poor reliability of braking system	Insufficient pressure in system	<p>Check pressure on tractor pressure gauge, wait till compressor fills tank to required pressure.</p> <p>Damaged air compressor in tractor Repair or replace.</p> <p>Damaged brake valve in tractor. Repair or replace.</p> <p>Leaking system conduits or connections. Check system for tightness.</p>
Excessive heating of axle hubs	Incorrect main or parking brake adjustment	Regulate setting of expander arms
	Worn brake linings	Change brake shoes
Incorrect hydraulic system operation	Improper hydraulic oil viscosity	Check oil quality, make sure that the oil in both machines is of the same type. If necessary change oil in tractor or in trailer.
	Insufficient tractor hydraulic pump output, damaged tractor hydraulic pump.	Check tractor hydraulic pump.
	Damaged or contaminated cylinder	Check cylinder rod (bending, corrosion), check cylinder for tightness (cylinder rod seal), if necessary, repair or replace the cylinder.
	Excessive cylinder loading	Check and reduce cylinder load, if necessary

FAULT	CAUSE	REMEDY
	Damaged hydraulic conduits	Check and ascertain that hydraulic conduits are tight, not fractured and properly tightened. If necessary, replace or tighten.
Excessive wear of left and right tyre shoulders on both sides.	Too low air pressure in tyres. Excessive speed of travel of loaded trailer on turns. Too fast loss of air due to damaged wheel, valve, puncture, etc.	Check air pressure. Regularly check correctness of air pressure in tyres. Excessive loading of the trailer. Do not exceed the permissible gross weight of the trailer. Reduce speed of travel while driving on turns on hardened surface. Check wheel and valve. Replace damaged parts.
Excessive wear of central part of tyre.	Excessive air pressure in tyres.	Check air pressure. Regularly check correctness of air pressure in tyres.
Excessive wear of left or right tyre shoulder, on one side	Incorrect toe-in. Incorrectly positioned wheel axles.	Damaged leaf spring on one side of the suspension system. Replace leaf springs.
Worn tyre tread.	Damaged suspension system, broken leaf spring. Damaged brake system, blocking of brakes, incorrectly adjusted brake system. Too frequent and violent braking.	Check suspension system for looseness, check leaf springs. Replace damaged or worn elements. Check brake system for malfunctions. Adjust expander lever.
Side crack.	Prolonged use of tyre with low air pressure. Excessive loading of the trailer.	Regularly check air pressure in tyres. Check weight of load while loading.
Abrasions on external side edge of tyre.	Too frequent driving over sharp or high obstacles (e.g. curbs).	Control driving technique.

FAULT	CAUSE	REMEDY
Damaged rim (hardening and cracking near rim), brittleness of tyre.	Incorrect braking technique. Too frequent violent braking. Damaged brake system.	Check brake system. Control braking technique. Damage occurs due to excessive heating of hub which leads to heating of wheel.

NOTES

A series of horizontal dotted lines for writing notes.



ANNEX A

Tyre dimensions

TRAILER VERSION	FRONT / REAR HALF AXLE
T679/3	500/50-17 14PR 149A8 ⁽¹⁾ 19.0/45-17 18PR 148A8 ⁽¹⁾
T679/4	500/50-17 14PR 149A8 ⁽¹⁾ 400/60 - 15.5 145A8 ⁽²⁾ 19.0/45-17 18PR 148A8 ⁽¹⁾

⁽¹⁾ - wheel disc 16.00x17"

⁽²⁾ - wheel discs 13.00x15.5" ET=-15